

# SICO STAGE & RISER CHOICES



[www.sicoinc.com](http://www.sicoinc.com)

# SICO Tri-Height Stage

The Sico Tri-Height Stage is a system that features three variable height adjustments, making for much more versatile staging. Set-up at a single level for meeting room stages, fashion runways, or head table settings. Set-up tiered configurations for seating or choral risers.

## Easy to operate:

- Requires minimal effort to set-up, keeping staffing requirements and labor costs to a minimum.

## Easy to set-up and take-down:

- Each section rolls in on 5-inch (13cm) swivel rubber casters and is quickly and easily set into place. The wheels lower automatically and engage to the floor as the unit is folded and rolled into storage.

## Less Units to be Handled:

- 6' x 8' (183cm x 244cm) stages make for the perfect head table riser. Allows 30" (76cm) for tables, 18" (46cm) for chairs, plus 24" (61cm) for serving space. 4' x 8' (122cm x 244cm) require twice as many units.

# 1



- Low see-through profile allows for easy movement of stage units.



- A spring assist pop-up feature assists in the deck reversal without dismantling a stage set-up.



- Rigid one piece unitized steel frame supports the decks. The decks nest firmly within the frames.



- More staging options! Reversible decks feature a combination of carpet and hard surface, or hard surface on both sides.

- Velcro on all sides of stage makes for quick and easy adjustable drape attachment. Drapes are adjustable, allowing for full deck-to-floor coverage at all heights.

- Tri-Height stages are designed to meet or exceed industry standards.

**Larger Decks Reduce Cost:**

- 6' x 8' (183cm x 244cm) stages require less units for staging configurations compared to 4' x 8' stages (122cm x 244cm).

**Security:**

- Over-center locking mechanism keeps legs locked into place during transport.

**Accessories:**

- Adjustable step units, ADA ramps, guard rails, guard rail covers, chair/table stops and drapes.

**Service:**

- Sico offers free space analysis drawings, which will provide accurate layouts for your venue with the appropriate number of stages and stage accessories.

**Specifications:**

- See specifications on page 10.



• Simply remove four bolts (with conventional allen wrench or power drill) to easily reverse deck surface.

• Two stages in one: carpet or hard surface.

• Changing heights is simple with the Sico built-in lock and pin mechanism. Just rotate the yellow handle and adjust to the desired height. Adjusts in 6" (15 cm) increments, adhering to ADA (Americans with Disabilities Act) requirements.

• Overlapping of decks in the riser set-up eliminates the possibility of chair legs sliding through. No additional chairstop required!

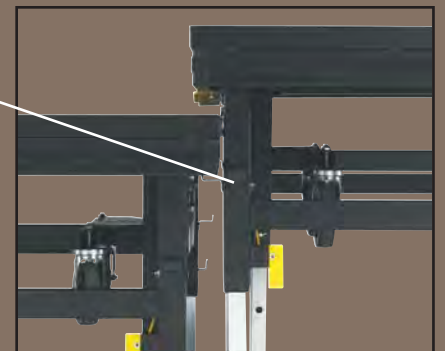

• The stage sections lock together with built-in unit-to-unit connectors when units are at the same or varying heights. No cords, Velcro, straps, or tape are necessary to hold stages in place.

# SICO 1800 Dual-Height Stage



The Dual-Height / Single Height 1800 series offers all the advantages of a mobile folding stage, plus the added simplicity and speed of built-in height adjustability.

## Single Person Set-up:

- Designed to be set-up and taken down by one person resulting in considerable savings in labor and time.

## Less Units to be Handled:

- 6' x 8' (183cm x 244cm) stages make for the perfect head table riser. Allows 30" (76cm) for tables, 18" (46cm) for chairs, plus 24" (61cm) for serving space. 4' x 8' (122cm x 244cm) require twice as many units.



- Over-center locking mechanism keeps legs locked into place during transport.



- Each section of a Sico 1800 mobile folding stage rolls freely on its own four casters. No heavy sections to lift and carry, no storage caddies necessary.



- Sico Adaptable Ramps allow the same fast set-up as you have with a Sico portable folding stage.

- Velcro on all four sides of stage make for easy drape attachment. Drapes are adjustable, allowing full deck-to-floor coverage at all heights.

- Vinyl coated steel edge banding provides long lasting wear and durability.

- Unit-to-unit lock for tiered riser or stage set-up guarantees that stages are locked together for safety and security.



- Sico's pin and cable operation allows for easy height adjustment.

**Accessories:**

- Adjustable step units, ADA ramps, guard rails, guard rail covers, chair/table stops and drapes.

**Service:**

- Sico offers free space analysis drawings, which will provide accurate layouts for your venue with the appropriate number of stages and stage accessories.

**Specifications:**

- See specifications on page 10.



- Ideal for head table risers, performance stages, fashion runways, speaker's platform and theatre-in-the-round.

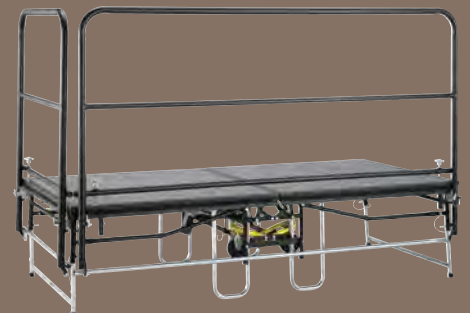
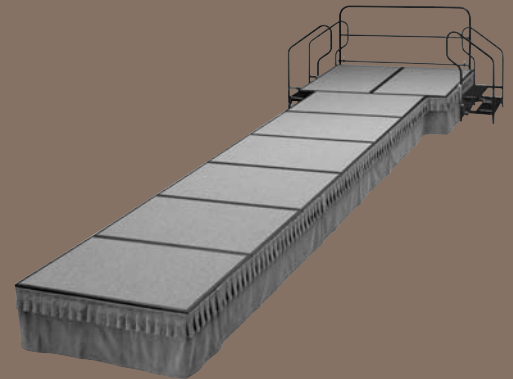
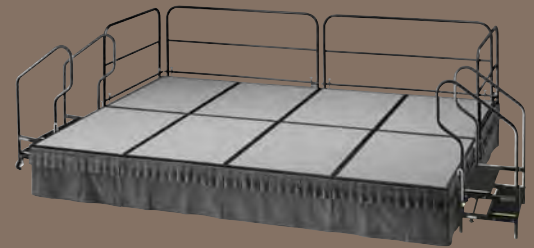

- Universal guardrails are used with the 1800 Stage, as well as the Sico Tri-Height stage.

# SICO X-Press® Stage & Riser

The Sico X-Press® is a stage and riser system designed to meet a facility's ever-changing needs. The X-Press® converts easily from one application to another without the necessity of lifting heavy folding leg units.

## Built to Stand-Up to your Needs:

- The Sico deck is structural, light-weight, and quiet. These features are made possible by a special resin impregnated honeycomb core, a solid edge, and complimented by our standard hard surface or carpeted surface.

## Lightweight Frame & Deck:

- The lightweight frames and decks allow for ease of handling. Available in 4' x 8' (122cm x 244cm) or 3' x 8' (91cm x 244cm) to meet your particular requirements. 3' x 8' units (91cm x 244cm) are recommended for riser configurations.

# 3



- Mobile caddies are available which hold up to 8 decks and frames, or 256 sq. ft. (24 sq.M) of staging for ease of storage and transport.

- Exclusive expanding rubber gasket at the base of each flex pin allows decks to be secured to the frames and sit flush with the deck surface.

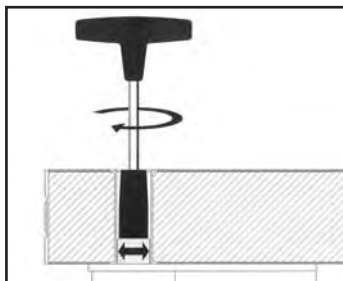

- Choose between a standard black hard surface, or a choice of carpet colors. Single sided or reversible decks are available.



- Snap action lock secures deck sections together in a stage or riser set-up.

**Sturdy:**

- 14 gauge unitized steel frame for long lasting strength and durability.  
Meets or exceeds industry standards!

**Flexible:**

- Available in a variety of heights with 6” (15cm) increments to meet ADA requirements.

**Accessories:**

Adjustable step units, ADA ramps, guard rails, guard rail covers, and drapes.

**Service:**

- Sico offers free space analysis drawings, which will provide accurate layouts for your venue with the appropriate number of stages and stage accessories.

**Specifications:**

- See specifications on page 11.



- Center frame legs have two adjustable glides to help level the stage on uneven surfaces.



- Heights are easily set with adjustable pull pins.

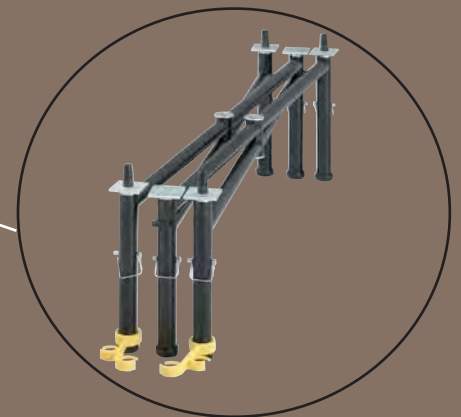

- The compact, light-weight frame is set in place, unfolded, and automatically assumes the correct position for attaching the deck.

# SICO Harmony Choral Risers

# 4

The innovative design of the Sico Harmony Choral Riser makes it easy to handle, quiet, and secure. The Harmony is available in both a three-tier and four-tier model.

## Easy to handle:

- Four wheel design means no lifting to transport. Everything is contained in one unit, no parts to carry or add on.

## Easy to fold:

- Transport and storage are easy for staff. One simple lifting motion makes it easy to fold up units. No disassembly required.

## One Person Operation

- Deck frames are welded aluminum to minimize weight.



- Guardrail folds down over unit and secures the risers in an upright position. Both 3 and 4 rise units will roll through a standard 36" (91cm) door.

- Carpet completely wraps tops and sides of all decks providing a quiet, acoustical asset to your performances. Carpet also eliminates the possibility of catching robes on sharp edges.

- One-inch (2.5 cm) deck-to-deck overhang reduces chances of accidents caused by heels slipping between riser tiers.

- The black frame offers an attractive appearance without reflective surfaces.

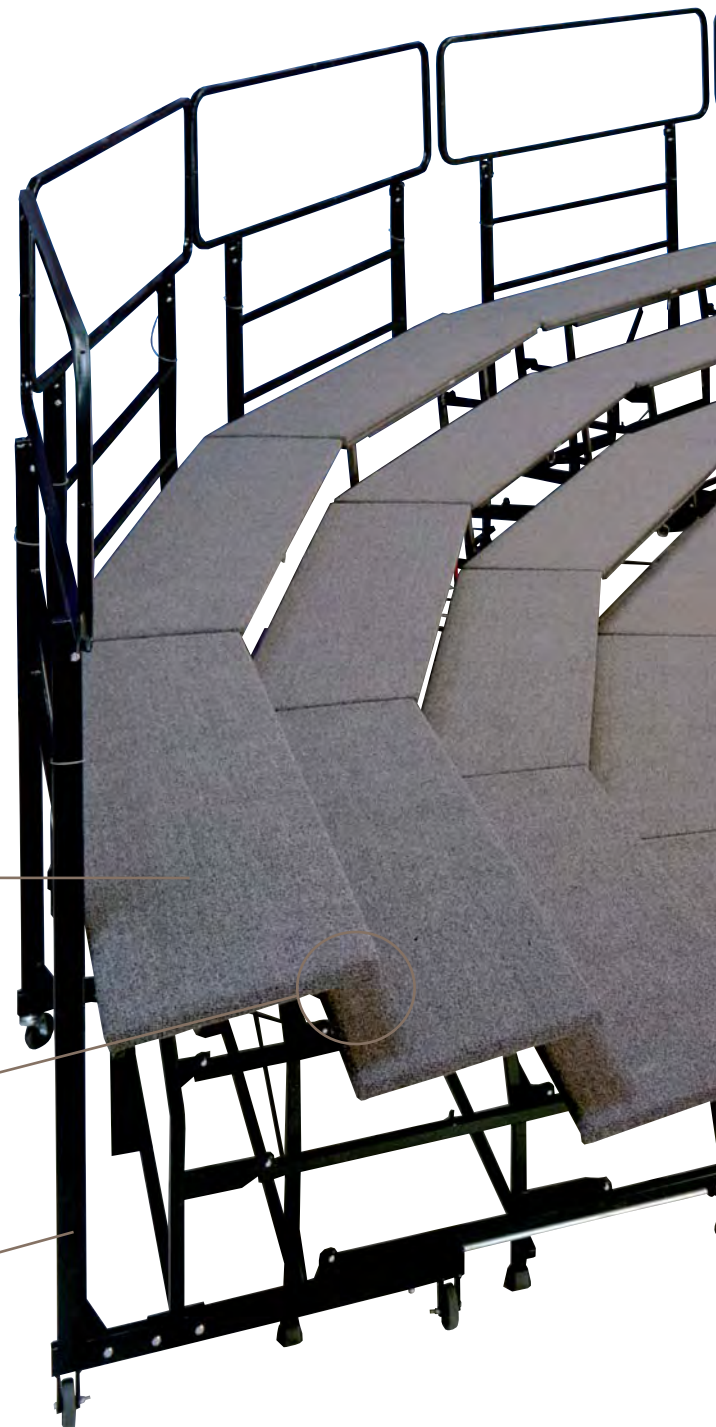

**Service:**

- Sico offers free space analysis drawings, which will provide accurate layouts for your venue with the appropriate number of choral risers.

**Specifications:**

- See specifications on page 11.

- The finish, design, and carpet will add a refined, professional look to your facility.



- Both the wheels and non-marking contact feet will not scratch floors, and are quiet, even on hard floors.

- Contact feet prevent sliding of risers as performers move about.

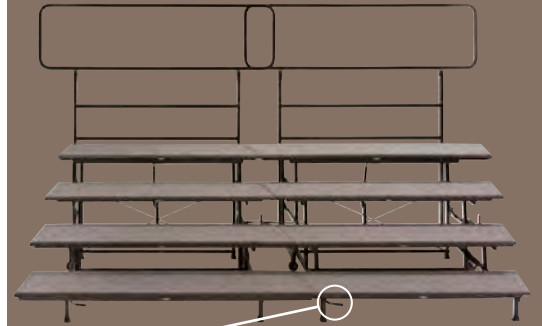

- Unit-to-unit cam connector draws units together and locks them in place. Nothing to unbolt or unscrew for set-up or take-downs.



- Exclusive deck locks allow quick configuration changes. Nearly instantaneous change of the deck arrangement from a curved to either a straight-line set-up, or a combination of curved and straight line. No tools required for change.

**Sico Tri-Height Stage Specifications:**

Model #	Length & Width	Height
S3H316C??41B	6'x8' (183cm x 244cm)	12"/18" (31/46 cm)
S3H316E??41B	6'x8' (183cm x 244cm)	18"/24"/30" (46/61/76 cm)
S3H316F??41B	6'x8' (183cm x 244cm)	24"/30"/36" (61/76/91 cm)
S3H316G??41B	6'x8' (183cm x 244cm)	30"/36"/42" (76/91/107 cm)
S3H314C??41B	4'x8' (122cm x 244cm)	12"/18" (31/46 cm)
S3H314E??41B	4'x8' (122cm x 244cm)	18"/24"/30" (46/61/76 cm)
S3H314F??41B	4'x8' (122cm x 244cm)	24"/30"/36" (61/76/91 cm)
S3H314G??41B	4'x8' (122cm x 244cm)	30"/36"/42" (76/91/107 cm)

Above Tri-Height model numbers for reversible decks (carpet on one side, hard surface on reverse side). Hard surface on both sides is available.

**Sico 1800 Stage Specifications:**

Model #	A: set-down ht.	B: storage ht.	C: storage width
<b>6' x 8' (183cm x 244cm)</b>			
1882-624	16" - 24" (41cm - 61cm)	60" (152cm)	17" (43cm)
1882-632	24" - 32" (61cm - 81cm)	68" (173cm)	21" (53cm)
1882-640	32" - 40" (81cm - 102cm)	76" (193cm)	21" (53cm)
<b>6' x 8' (183cm x 244cm)</b>			
1881-608	8" (20cm)	52" (132cm)	16 1/2" (42cm)
1881-616	16" (41cm)	60" (152cm)	17" (43cm)
1881-624	24" (61cm)	68" (173cm)	21" (53cm)
1881-632	32" (81cm)	76" (193cm)	21" (53cm)
1881-640	40" (102cm)	84" (213cm)	23" (58cm)
<b>4' x 8' (122cm x 244cm)</b>			
1882-424	16" - 24" (41cm - 61cm)	60" (152cm)	17" (43cm)
1882-432	24" - 32" (61cm - 81cm)	68" (173cm)	21" (53cm)
1882-440	32" - 40" (81cm - 102cm)	76" (193cm)	21" (53cm)
<b>4' x 8' (122cm - 244cm)</b>			
1881-408	8" (20cm)	52" (132cm)	16 1/2" (42cm)
1881-416	16" (41cm)	60" (153cm)	17" (43cm)
1881-424	24" (61cm)	68" (173cm)	21" (53cm)
1881-432	32" (81cm)	76" (193cm)	21" (53cm)
1881-440	40" (102cm)	84" (213cm)	23" (58cm)
<b>3' x 8' (91cm x 244cm)</b>			
1881-308	8" (20cm)	52" (132cm)	16 1/2" (42cm)
1881-316	16" (41cm)	60" (152cm)	17" (43cm)
1881-324	24" (61cm)	68" (173cm)	21" (53cm)
1881-332	32" (81cm)	76" (193cm)	21" (53cm)

Above model numbers for Tuff-Deck (hard surface). For carpeted deck, change the third digit to a "1". For example: 1811-416 = carpeted stage 4' x 8' - 16" high (122cm x 244cm - 41cm)

**Please contact Sico sales for your accessory needs: guardrails, steps, ramps, and drapes.**

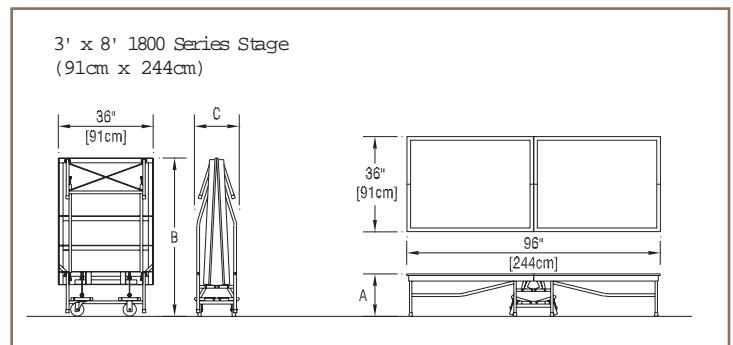
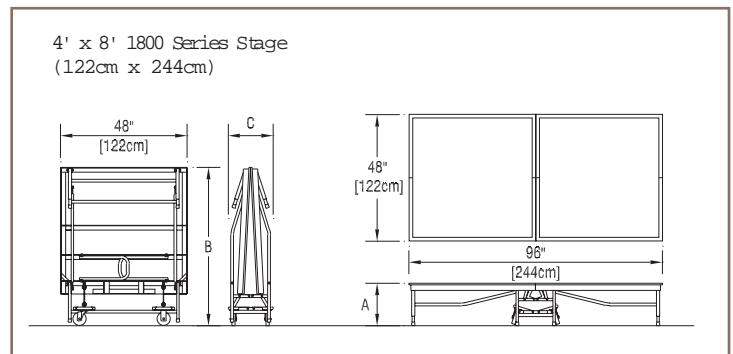
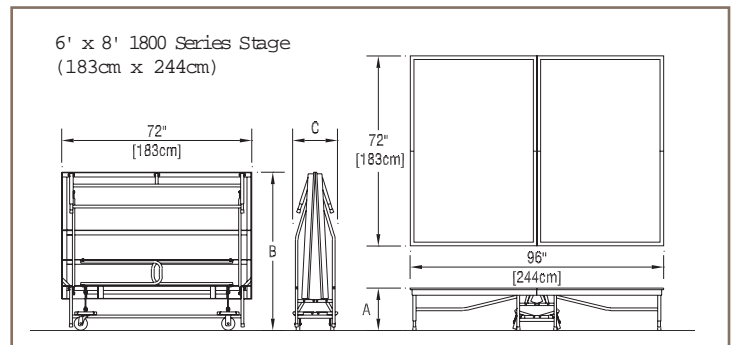
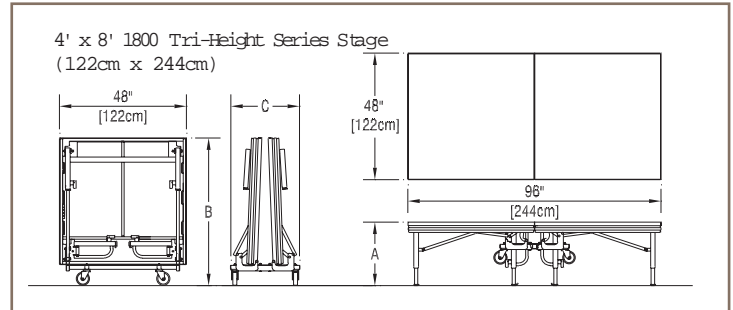
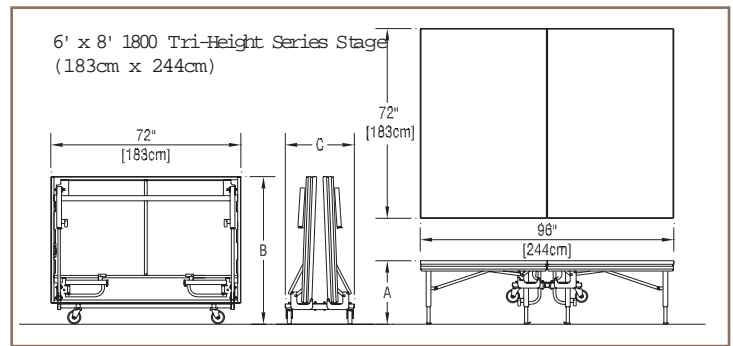

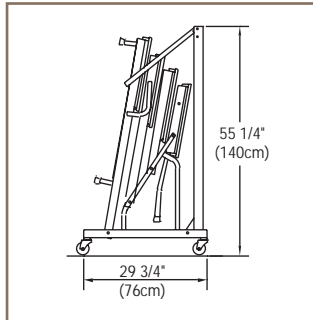
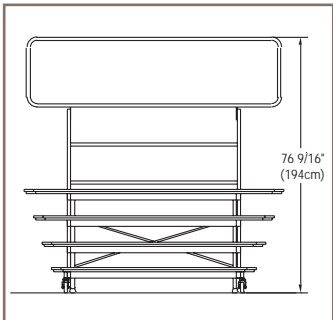
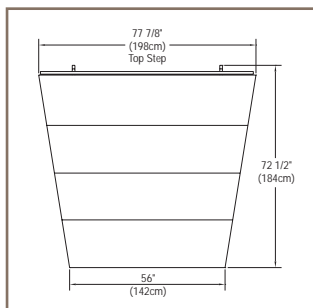
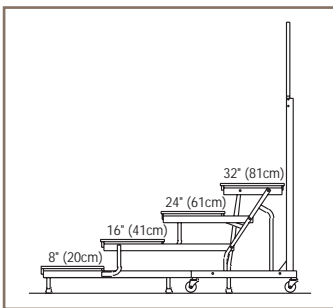
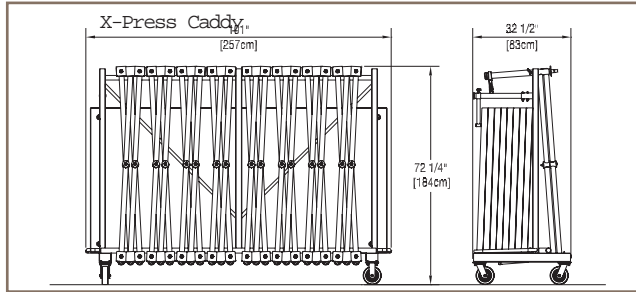
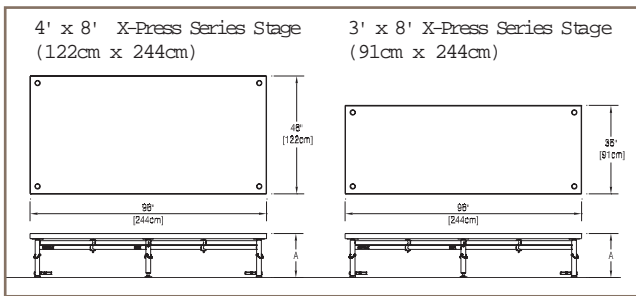

END VIEW

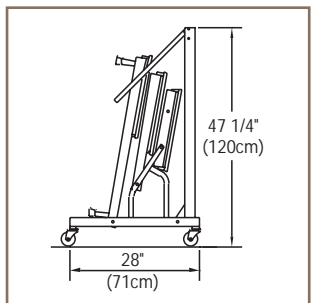
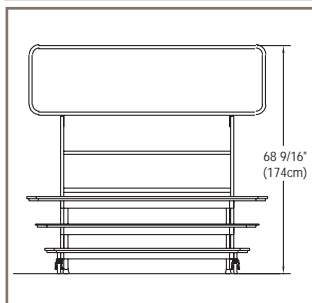
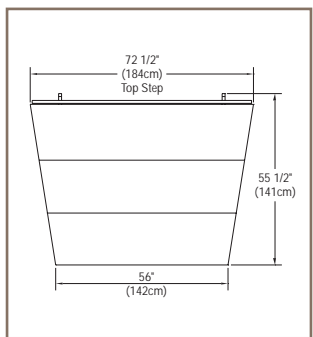
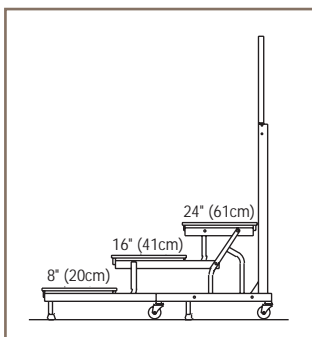

END VIEW

**Sico X-Press Stage Specifications:**

Model # Decks	Description: Decks	Model # Frames	Description: Frames
SND144401	4' x 8' Tuff-Deck / Non-reversible (122cm x 244cm)	SNM124AB	4' x 8' / 6" high * (122cm x 244cm)
SND144XXX	4' x 8' Carpet / Non-reversible (122cm x 244cm)	SNM124BB	4' x 8' / 12" high (122cm x 244cm)
SND144XXXR	4' x 8' Tuff-Deck/Carpet Reversible (122cm x 244cm)	SNM124CB	4' x 8' / 18" - 24" high (122cm x 244cm)
SND143401	3' x 8' Tuff-Deck / Non-reversible (91cm x 244cm)	SNM124DB	4' x 8' / 24"-30"-36" high (122cm x 244cm)
SND143XXX	3' x 8' Carpet / Non-reversible (91cm x 244cm)	SNM123AB	3' x 8' / 6" high * (91cm x 244cm)
SND143XXXR	3' x 8' Tuff-Deck/Carpet (91cm x 244cm)	SNM123BB	3' x 8' / 12" high (91cm x 244cm)
SAX12FXXX	4' x 4' Corner-Section / Floor Standing (122cm x 122cm)	SNM123CB	3' x 8' / 18" - 24" high (91cm x 244cm)
SAX12SXXX	4' x 4' Corner-Section / Stage Mounted (122cm x 122cm)	SNM123DB	3' x 8' / 24"-30"-36" high (91cm x 244cm)

\*6" (15cm) high frames are non-folding.

- The 3' x 8' (91cm x 244cm) lightweight frame weighs only 67 lbs. (30 kg). The 4' x 8' (122cm x 244cm) lightweight frame weighs only 70 lbs. (32 kg).
- The 3' x 8' (92cm x 243cm) deck weighs only 84 lbs. (38 kg) and the 4' x 8' (122cm x 244cm) deck weighs only 96 lbs. (44 kg).

**Harmony 4-RISE MODEL #2610-432 Specifications:\***

UNITS	GROUP CAPACITY	WIDTH & DEPTH
2	32-40	12' 10" x 6' 11 1/2" (391cm x 212cm)
3	48-61	18' 10 1/2" x 7' 7 3/4" (575cm x 233cm)
4	64-82	24' 5" x 9' 1/2" (744cm x 276cm)
5	80-103	29' 4 1/2" x 10' 4 1/4" (895cm x 316cm)
6	96-124	33' 7 3/4" x 12' 3 1/4" (1026cm x 374cm)
7	112-145	37' 3/4" x 14' 3/4" (1130cm x 429cm)
8	128-166	39' 7 3/4" x 16' 4" (1208cm x 498cm)
9	144-187	41' 1 1/2" x 18' 5" (1253cm x 561cm)
10	160-208	41' 8" x 20' 10 1/2" (1270cm x 636cm)

First capacity number: Performers shoulder to shoulder. Second capacity number: Performers facing center, shoulders turned in.

\* Cloud Gray carpet only. Depth of risers is measured in curved configuration.

**Harmony 3-RISE MODEL #2610-324 Specifications:\***

UNITS	GROUP CAPACITY	WIDTH & DEPTH
2	24-32	11'11" x 5' 3 3/4" (363cm x 162cm)
3	36-48	17' 6 1/2" x 5' 11 3/4" (535cm x 182cm)
4	48-64	22' 9" x 7' 5 1/4" (693cm x 227cm)
5	60-80	27' 5 1/2" x 8' 10" (837cm x 269cm)
6	72-96	31' 5 1/2" x 10' 8 3/4" (959cm x 327cm)
7	84-112	34' 8" x 12' 6 3/4" (1057cm x 383cm)
8	96-128	37' 1/2" x 14' 10 1/2" (1129cm x 453cm)
9	108-144	38' 6" x 16' 11 3/4" (1173cm x 518cm)
10	120-160	39' 1/2" x 19' 6" 1/4" (1190cm x 595cm)

First capacity number: Performers shoulder to shoulder. Second capacity number: Performers facing center, shoulders turned in.

\* Cloud Gray carpet only. Depth of risers is measured in curved configuration.

# THE SICO FAMILY OF PRODUCTS

## Performance Stages



Fold N' Set Stages



Folding Leg Stages/Risers



Venue Maker Stages

## Tables



Pacer Mobile Folding Banquet Tables



2-Tier Banquet Tables



Tri-Fold Mobile Folding Room Service Tables



Multiple Application Mobile Folding Tables



Multi-Height Pre-Event Mobile Folding Tables



Mobile Folding Cafeteria Tables



ConverTable Auditorium Bench / Tables



Mobile Folding Boardroom/Conference Tables



SOPHISTICATE® Upscale Catering Tables

## Portable Dance Floors



Starlight Dance Floor



Original Parquet Dance Floor



Cam-Lock Parquet Dance Floor



Cam-Lam Dance Floor

## Buffet Stations



## Mobile Sleepers



## Insta-Theatre®



## Luggage Carts



[www.sicoinc.com](http://www.sicoinc.com)

**The Americas**  
SICO AMERICA INC.  
7525 Cahill Road  
Minneapolis, MN 55439 USA  
In U.S. Phone (800) 328-6138  
Outside U.S. (952) 941-1700  
Fax (952) 941-6688  
e-mail: [sales@sicoinc.com](mailto:sales@sicoinc.com)

**Australasia & South Africa**  
SICO SOUTH PACIFIC  
Lot 3 Blade Close  
Berkeley Vale, NSW 2261  
Australia  
Phone [61] (2) 4336-1333  
Fax [61] (2) 4388-4643  
e-mail: [sales@sicosp.com.au](mailto:sales@sicosp.com.au)

**Europe**  
SICO EUROPE LTD.  
The Link Park  
Lympe Industrial Estate  
Lympe, Kent CT21 4LR  
England  
Phone [44] (1303) 234000  
Fax [44] (1303) 234001  
e-mail: [sales@sico-europe.com](mailto:sales@sico-europe.com)

**Asean Countries, Korea & India**  
SICO ASIA PTE LTD.  
1 Clementi Loop #06-01  
Singapore 129808  
Phone (65) 6500-0800  
Fax (65) 6500-0811  
e-mail: [sales@sicoasia.com](mailto:sales@sicoasia.com)

**Japan**  
SICO JAPAN  
Izumishoji Bldg. 4F  
4-2-6, Kojimachi, 4-Chome  
Chiyoda-ku, Tokyo 102-0083  
Japan  
Phone [81] (3) 3288-0145  
Fax [81] (3) 3288-0146  
e-mail: [sales@sico-japan.com](mailto:sales@sico-japan.com)

**China**  
SICO-SST  
Rm. 1906, Chaowai SOHO  
Tower A, B6  
Chaowai St. Chaoyang District  
Beijing, 100020  
Peoples Republic of China  
Phone [86] (10) 5900-2789  
Fax [86] (10) 5900-2780  
e-mail: [sales@sico-sst.com](mailto:sales@sico-sst.com)