



Owner's Manual

DECO SERIES MOBILE BUFFET STATION SOLUTIONS

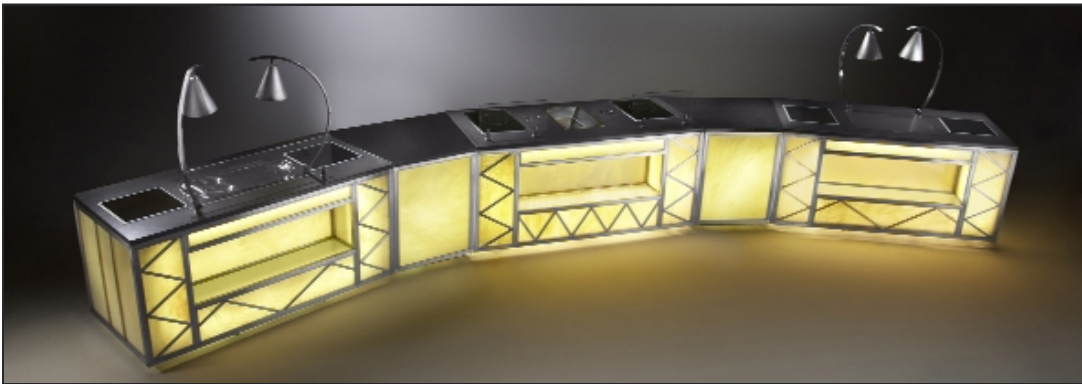

TABLE OF CONTENTS:

- Introduction*.....1
- Safety Information*.....2 - 4
- Installation and Setup*.....5 - 10
- Operating Instructions*.....11 - 15
- Care and Cleaning*.....16 - 17
- Troubleshooting Guide*.....18 - 19
- Warranty Information*20
- Service Information*.....21

For Future Reference, Please fill in the Information below for your buffet station:

Model Number(s): _____

Serial Number(s): _____



Introduction

Thank you for purchasing your new SICO® Deco Series Mobile Buffet Station. We appreciate your business and rest assured, you can feel confident that you have made the right purchase decision. It is our pleasure to provide you with a product that will perform to your every expectation and embodies the high quality standards and service that SICO® is known for around the globe.

Your satisfaction is our #1 priority at SICO®. For over 50 years, SICO® has been a leading, worldwide manufacturer of mobile folding products to help facilities maximize the efficient use of their space. From our renowned portable dance floors to our full line of mobile folding tables and easy to use mobile folding stages, we offer a host of innovative products that offer the same ingenuity and quality that so many of our customers have come to expect from SICO®.

Should service become necessary, your SICO® Deco Series Mobile Buffet Station is backed by one of the finest warranties in the industry. Please take a moment to review the warranty information on page 20.

This owner's manual will answer most of questions concerning the features, operation and care of your new SICO® Deco Series Mobile Buffet Station. If you find you have a question not addressed here, please do not hesitate to contact SICO® Customer Care at 1-800-424-0796 or by any of the other means of correspondence given in the service section of this manual.

Once again, from the entire staff at SICO®, we thank you for choosing our products and look forward to serving you again in the future.



Safety and Precautions

As you read the information provided in this manual, please pay particular attention to the CAUTION and WARNING symbols as they appear. This information is very important to all users for the safe and efficient operation of SICO's Deco Series Buffet products.

	CAUTION
<i>Designates a situation where injury or product damage may occur if instructions are not followed.</i>	

	WARNING
<i>Designates a HAZARD that may result in a serious injury or death if precautions are not followed.</i>	

In addition, throughout this manual you may find that signals an IMPORTANT NOTE, which highlights information that should be noted.

	WARNING
For your safety, the information in the manual must be followed to minimize the risk of fire, explosion, electrical shock or to prevent property damage, personal injury or loss of life.	

	WARNING
Dependent on the features of each unit, proper electrical service MUST be supplied to each SICO® Deco Series Buffet Station in accordance with local codes. Installation and service should be performed by a qualified installer or service agency. ALL UNITS MUST BE PROPERLY GROUNDED TO AVOID INJURY OR LOSS OF LIFE. DO NOT attempt to alter or replace any part unless recommended in this manual.	



Safety and Precautions

- ◆ Use this appliance only for its intended use as described in this manual.
- ◆ Before performing any cleaning or service, disconnect all supplied power to the unit.



CAUTION

Persons with a pacemaker or similar medical device should exercise caution when using or standing in close proximity with an induction cooking/warming unit while it is in operation. Electromagnetic fields generated by such devices may affect the function of the pacemaker or similar medical device. It is advisable to consult a doctor or the manufacturer of the medical device in such cases.

- ◆ For units provided with induction cooking and/or warming appliances, fully familiarize yourself with the operation of induction units as described in the provided manuals.
- ◆ Use proper pan sizes. The detection sensors will not allow the affected cooking element to function without a pan present. Use cookware that is flat bottomed and fully covers the cooking surface for best results.
- ◆ To avoid the risk of burns, use caution when using metal utensils. If left in close proximity to the induction unit, these utensils may become hot.
- ◆ Keep unopened canned goods a safe distance away from the induction surface, they may become heated causing internal pressure which may burst, causing injury.
- ◆ Do not store flammable liquids on or near this or any other heating appliance.
- ◆ Never leave prepared food on the cooking elements unattended. Boilovers and greasy spills may ignite causing fire and/or smoke or a pan that has been boiled dry may melt or become damaged.
- ◆ Protective liners. Do not use aluminum foil on or near the cooking/warming surface. aluminum foil may be used after the cooking process is complete. Any other use of aluminum foil may result in electrical shock, fire or short circuit.
- ◆ Avoid placing objects near the keypad controls in order to avoid accidental activation or adjustment of the control settings.



Safety and Precautions

- ◆ Always keep towels, cloths and/or pot holders a safe distance from the heating surface. Avoid wearing loose fitting or hanging garments while operating. Flammable materials could be ignited causing severe burns.
- ◆ Use only dry pot holders. Moist or damp pot holders transfer heat quickly and may cause burns from steam.
- ◆ Do not use water to extinguish grease fires. Turn controls off if possible and smother the flaming pan by covering it with a well fitting lid , baking sheet or flat metal tray. Flaming spills outside the pan can put out with baking soda. If necessary, use a multipurpose dry chemical or foam type fire extinguisher. NEVER attempt to move a flaming pan.
- ◆ Do not touch glass surface elements while cooking or warm holding. Surfaces may be hot enough to burn even though they appear dark in color.
- ◆ Deep fat frying is not recommended unless proper ventilation and proper safety precautions can be provided.
- ◆ Maintaining a clean cooking surface will prevent accumulation of grease or other spills which may ignite. Spilled foods may also cause accidental activation or deactivation of the control pad surface. It is especially important to always keep this area clean and clear of spills. See the cleaning guidelines listed in this manual for more information.
- ◆ Choose cookware with easily grasped handles. Always turn pan handles inward to avoid accidental spills. Handles should not extend over adjacent work areas or other heating surfaces.
- ◆ Never use the heating surface as a cutting board.
- ◆ DO NOT operate the induction unit if the glass heating surface is cracked or broken. Spillovers and/or cleaning solutions may penetrate a broken surface creating a significant risk of electrical shock. Contact a qualified service technician immediately should your heating surface become cracked or broken.
- ◆ To avoid possible damage to the heating surface, it is recommended that you avoid cleaning the surface until it has cooled. The exception to this is food spills with high sugar content such as jams, jellies or fudge or any melted plastics which can cause permanent damage to the heating surface if not immediately removed. See the cleaning guidelines section in this manual for more information.



Installation and Setup

WARNING

For your safety, the information in the manual must be followed to minimize the risk of fire, explosion, electrical shock or to prevent property damage, personal injury or loss of life.

WARNING

Depending on the features of each unit, proper electrical service **MUST** be supplied to each SICO® Deco Series Buffet Station in accordance with local codes. Refer to each units individual rating tag for more specific electrical requirements. Installation and service should be performed by a qualified installer or service agency. **ALL UNITS MUST BE PROPERLY GROUNDED TO AVOID INJURY OR LOSS OF LIFE. DO NOT attempt to alter or replace any part unless recommended in this manual.**

The new SICO® Deco Series Mobile Buffet Stations are designed for minimal setup time and ease of operation. Many unit configurations arrive fully assembled and ready for use, simply roll to the intended location and provide electrical power as needed.

Any unit that requires assembly before use will have specific instructions packaged with the unit. If you have any questions or concerns during this initial setup, please contact SICO® Customer Care at 1-800-424-0796.

Each unit will have different electrical requirements to operate lighting, warming and cooking equipment. Listed below are the baseline electrical requirements for each station. Again, see each units electrical rating tag for more sepcific information:



Load Rating:

Induction Warming units : 3.4A each @ 120VAC
LED lighting: .4 A @ 120VAC
Total Load: 10.6A @ 120VAC
Unit supplied with single NEMA 5-20P plug.

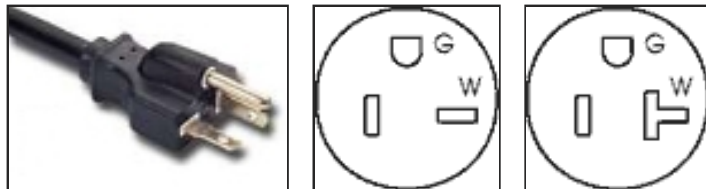



Installation and Setup

WARNING

Dependent on the features of each unit, proper electrical service **MUST** be supplied to each SICO® Deco Series Buffet Station in accordance with local codes. Refer to each units individual rating tag for more specific electrical requirements. Installation and service should be performed by a qualified installer or service agency. **ALL UNITS MUST BE PROPERLY GROUNDED TO AVOID INJURY OR LOSS OF LIFE. DO NOT attempt to alter or replace any part unless recommended in this manual.**

Deco Induction Warming & Hotplate Station



Load Rating:

- Induction Warming units : 3.4A each @ 120VAC
- Hotplate unit: 3.6A each @ 120VAC
- LED lighting: .4 A @ 120VAC
- Heat lamp Lighting: 4.2A @ 120VAC (250w Bulbs)
- Total Load: 15A @ 120VAC
- Unit supplied with single NEMA 5-20P plug.

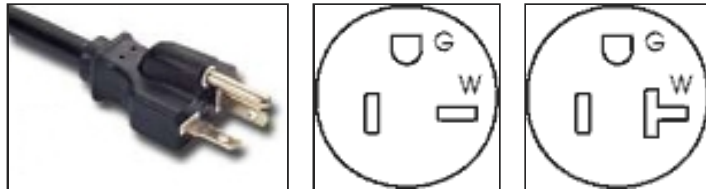

Deco Hotplate Warming Station



Load Rating:

- Hotplate unit: 10.2A @ 120VAC
- LED lighting: .4 A @ 120VAC
- Heat lamp Lighting: 8.3A @ 120VAC (250w Bulbs)
- Total Load: 18.9A @ 120VAC
- Unit supplied with single NEMA 5-20P plug.

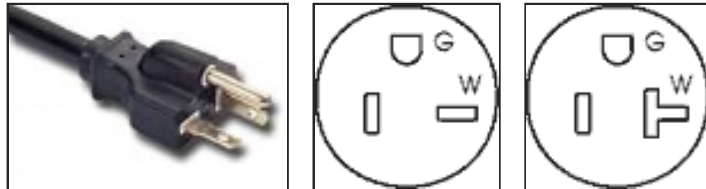



Installation and Setup



WARNING

Dependent on the features of each unit, proper electrical service **MUST** be supplied to each SICO® Deco Series Buffet Station in accordance with local codes. Refer to each units individual rating tag for more specific electrical requirements. Installation and service should be performed by a qualified installer or service agency. **ALL UNITS MUST BE PROPERLY GROUNDED TO AVOID INJURY OR LOSS OF LIFE. DO NOT attempt to alter or replace any part unless recommended in this manual.**

Deco Cooking Station (110V)



Load Rating:

Induction Cooking units: 15A @ 120VAC
LED lighting: .4 A @ 120VAC
Total Load: 30.4A @ 120VAC
Unit supplied with dual (2) NEMA 5-20P plugs.
(Dedicated circuits are required to operate this unit)

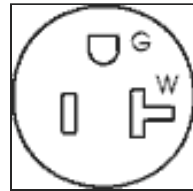
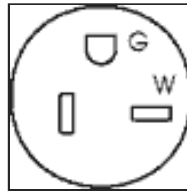

Deco Cooking Station (240V)



Load Rating:

Induction Cooking units: 7.5A @ 240VAC
LED lighting: .2 A @ 240VAC
Total Load: 15.2A @ 240VAC
Unit supplied with NEMA 6-15P plug.

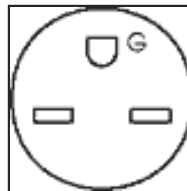



Installation and Setup



WARNING

Dependent on the features of each unit, proper electrical service **MUST** be supplied to each SICO® Deco Series Buffet Station in accordance with local codes. Refer to each units individual rating tag for more specific electrical requirements. Installation and service should be performed by a qualified installer or service agency. **ALL UNITS MUST BE PROPERLY GROUNDED TO AVOID INJURY OR LOSS OF LIFE. DO NOT attempt to alter or replace any part unless recommended in this manual.**

Deco Carving and Induction Warming Station



Load Rating:

Induction Warming units : 3.4A each @ 120VAC

Carving Tray Heater: 5A each @ 120VAC

LED lighting: .4 A @ 120VAC

Heat lamp Lighting: 4.2A @ 120VAC (250w Bulbs)

Total Load: 16.4A @ 120VAC

Unit supplied with single NEMA 5-20P plug.

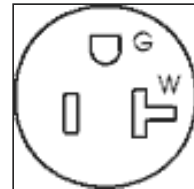
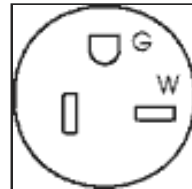

Deco Multi-Purpose Station



Load Rating:

LED lighting: .4 A @ 120VAC

Accessory Outlets: 15A @ 120VAC (Total Max Load)

Total Load: 16A @ 120VAC (Maximum)

Unit supplied with single NEMA 5-20P plug.

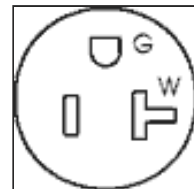
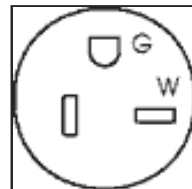



Installation and Setup



WARNING

Dependent on the features of each unit, proper electrical service **MUST** be supplied to each SICO® Deco Series Buffet Station in accordance with local codes. Refer to each units individual rating tag for more specific electrical requirements. Installation and service should be performed by a qualified installer or service agency. **ALL UNITS MUST BE PROPERLY GROUNDED TO AVOID INJURY OR LOSS OF LIFE. DO NOT attempt to alter or replace any part unless recommended in this manual.**

Deco Food & Beverage Display Station

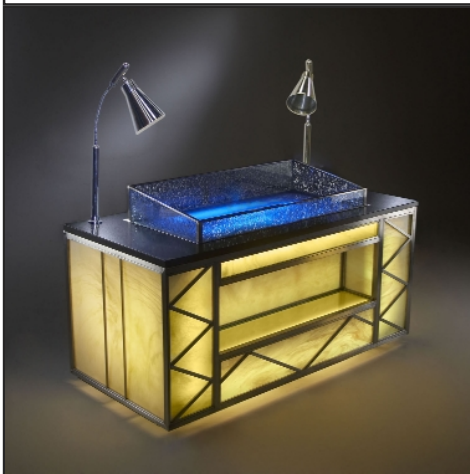

Load Rating:

Display Lighting: 1A @ 120VAC Nominal
LED lighting: 1A @ 120VAC Nominal
Total Load: 2A @ 120VAC Nominal
Unit supplied with single NEMA 5-15P plug.



Deco Bar Station



Load Rating:

LED lighting: 1A @ 120VAC Nominal
Total Load: 1A @ 120VAC Nominal
Unit supplied with single NEMA 5-15P plug.





Installation and Setup



WARNING

Dependent on the features of each unit, proper electrical service **MUST** be supplied to each SICO® Deco Series Buffet Station in accordance with local codes. Refer to each units individual rating tag for more specific electrical requirements. Installation and service should be performed by a qualified installer or service agency. **ALL UNITS MUST BE PROPERLY GROUNDED TO AVOID INJURY OR LOSS OF LIFE. DO NOT attempt to alter or replace any part unless recommended in this manual.**

Deco Trapezoid Side Station



Load Rating:

LED lighting: 1A @ 120VAC Nominal
Total Load: 1A @ 120VAC Nominal
Unit supplied with single NEMA 5-15P plug.



Deco Trapezoid Side Station with Ice Bin



Load Rating:

LED lighting: 1A @ 120VAC Nominal
Total Load: 1A @ 120VAC Nominal
Unit supplied with single NEMA 5-15P plug.

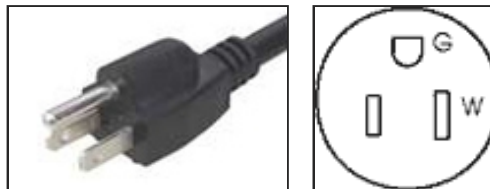



WARNING

For your safety, the information in the manual must be followed to minimize the risk of fire, explosion, electrical shock or to prevent property damage, personal injury or loss of life.

Induction Cooking and Chafing Surfaces

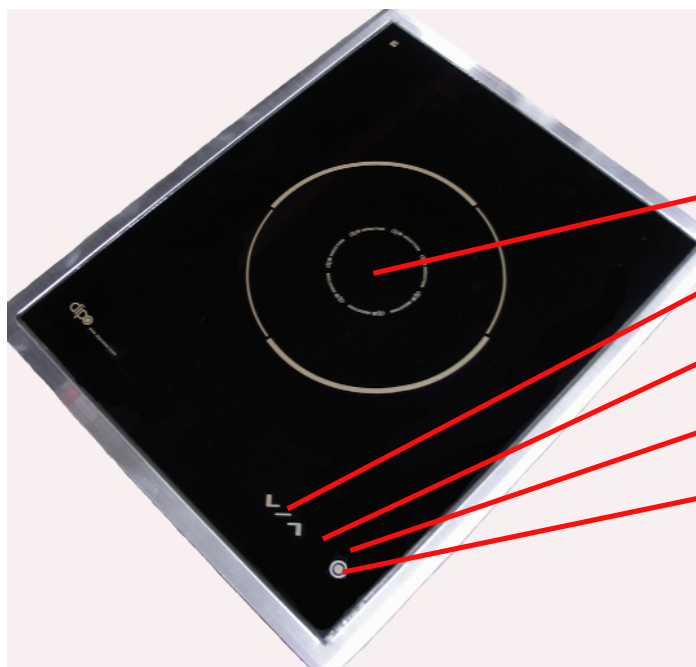

- 1) Induction Zone
- 2) Temperature Controls
- 3) Display
- 4) Power Indicator
- 5) Power Button

Induction Unit Features and Functions:

- 1) **Induction Zone:** This area indicates the central location of the induction zone where cookware should be placed.
- 2) **Temperature Controls:** Used to adjust cooking and warming temperature settings.
- 3) **Display:** Indicates temperature setting, cookware sensing and numerical error codes. If the cooking vessel is undersized, unsuitable or missing, a blinking “U” will be shown. See the Troubleshooting section of this manual for a description of error codes.
- 4) **Power Indicator:** A small red indicator will show that the unit is receiving power and is ready to be used.
- 5) **Power Button:** Initiates Cooking/Warming function. The unit will indicate a “zero” at startup giving the indication that the unit is ready for temperature adjustment.



General Operating Instructions

Induction Chafing (Warming) Surfaces

- ◆ Carefully review the Safety and Precautions section of this manual for important notes regarding the care and use of induction cooking and chafing units.
- ◆ Use only induction certified chafing dishes. Certain grades of stainless steel used to manufacture chafing dishes are non-magnetic and unsuitable for use with induction heating technology. In general, use vessels made from 400 series stainless steel.
- ◆ It is recommended that chafing dishes should be filled with hot water. This will decrease the time it will take the chafing dish to reach safe food holding temperature.
- ◆ The results of temperature settings may vary due to the differences in materials and the preparation environment. The following will serve as a general guideline:

- 1 - 130°F / 54°C
- 2 - 140°F / 60°C
- 3 - 160°F / 71°C
- 4 - 175°F / 79°C
- 5 - 200°F / 93°C

Induction Cooking Surfaces

- ◆ Carefully review the Safety and Precautions section of this manual for important notes regarding the care and use of induction cooking and chafing units.
- ◆ Use only induction certified cookware. Cookware must be constructed of ferrous (magnetic) metals to be used with induction cooking and warming. Glass, Ceramic, Aluminum, Bronze, Copper and even certain grades of stainless steel used to manufacture cookware are non-magnetic and unsuitable for use with induction heating technology. When choosing cookware, a simple test to determine whether a cooking vessel is suitable is to place a magnet to its surface. Typically, use cookware made from 400 series stainless steel, cast iron or certified enamelware.
- ◆ The results of temperature settings may vary due to the differences in materials and the preparation environment. The following will serve as a general guideline:

- 1 - 95°F / 35°C
- 2 - 125°F / 52°C
- 3 - 175°F / 79°C
- 4 - 250°F / 121°C
- 5 - 300°F / 148°C
- 6 - 350°F / 177°C
- 7 - 400°F / 204°C
- 8 - 450°F / 232°C

Hotplate Warming Surfaces

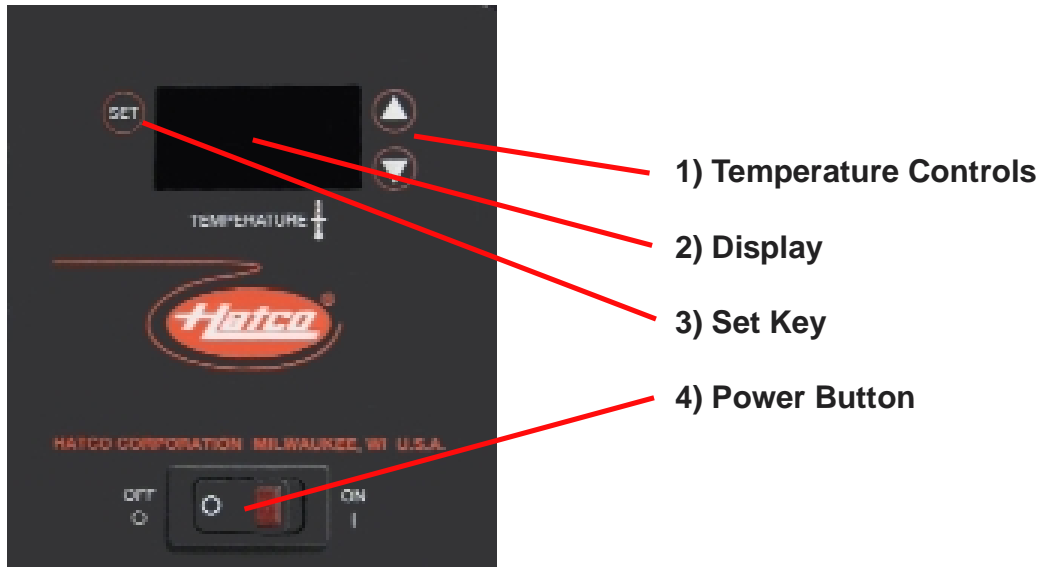

Hotplate Unit Features and Functions:

- 1) **Temperature Controls:** Used to adjust warming temperature settings.
- 2) **Display:** Indicates temperature setting.
- 3) **Set Key:** Used to enter a setpoint temperature value into memory.
- 4) **Power Button:** Provides power to the warming plate. The indicator light in this switch will glow red indicating the unit is in use.

Programming Sequence:

- 1) Press the key once to view the setpoint temperature value.
- 2) Press the key again to display the *current* temperature value.
- 3) Press the up or down temperature control keys to select the desired setpoint value. Pressing and holding either of the keys will rapidly advance the setpoint value.
- 4) Press the set key to complete the programming sequence and enter the value into memory. The display will go blank for approx. 2 seconds to acknowledge the end of the programming sequence and acceptance of the setpoint temperature value.
- 5) The unit will now automatically heat to the setpoint value each time the unit is powered on.

General Operating Instructions

LED Lighting

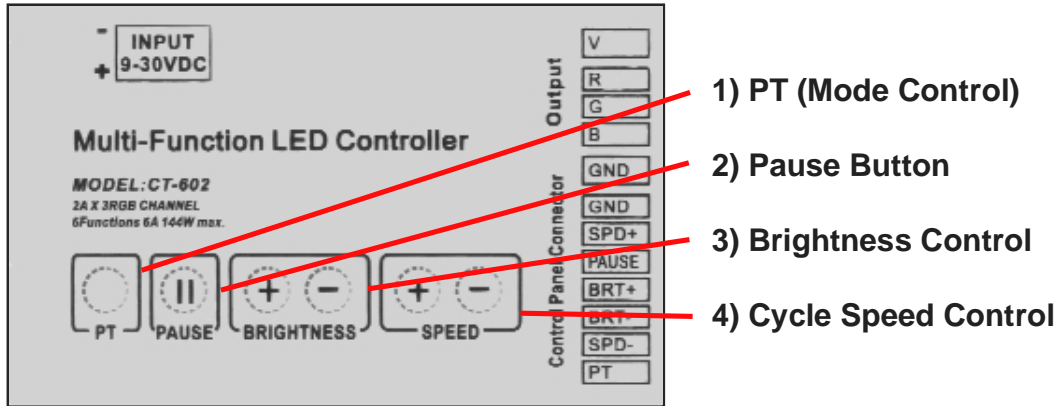

- ◆ Carefully review the Safety and Precautions section of this manual for important notes regarding the care and use of the LED lighting components and controls.
- ◆ An indicator strip is provided next to the LED operating console. This will give the user the ability to preview LED settings as they are changed.

Operating Instructions:

1) PT Button: Press the PT button to change the desired mode.

Mode 1: Seven color gradual change. This setting changes gradually between the seven main colors.

Mode 2: Leaning gradual change. This setting changes gradually between the seven available colors with gradient color changes providing an infinite number of colors.

Mode 3: Seven color change. Each time you press the PT button, it will select one of the seven main colors individually.

2) Pause: Press the Pause button to pause the LED sequence at its current color setting.

3) Brightness +/- : Changes the brightness of the entire LED circuit. Default setting is at the brightest setting.

4) Speed +/- : Changes the cycle speed at which the LED lighting changes colors. Default setting is at the fastest speed.



General Operating Instructions

Display & Heatlamp Lighting

- ◆ All lighting is controlled at the power center located in the lower cabinet. Simply turn on the power strip to provide power to the unit and all lighting.
- ◆ If bulbs need replacement during use, unplug the powercord that provides power to the light fixtures and allow ample time for cooling before replacement.
- ◆ Use only properly rated replacement bulbs. For heatlamp applications, standard 250 watt infrared heatlamps are recommended. For display lighting applications, any standard medium E-27 base bulb in your choice of color and wattage will suffice.
- ◆ As in all food display/preparation environments, it is always recommended to use shatter resistant bulbs.

Carving Stations with Heated Carving Tray

- ◆ The carving tray heating element is controlled at the power center located in the lower cabinet. Simply turn on the power strip to provide power to the unit and the carving tray heater.
- ◆ Remove the vented cap on the top surface of the carving tray and fill with hot water. The heating element will maintain the tray temperature of approximately 200°F / 93°C automatically. For best results, make sure the carving tray always has sufficient water to accommodate uniform heating of the tray surface.

Food & Beverage Display Stations with Ice Bins

- ◆ For best results, fill the ice display approximately 1/3 to half full. Proceed to make your arrangement of items in the display. If needed, add additional ice to surround the displayed items if they require additional cooling.



CAUTION

The drainage system is continuous . It is very important for operators to be mindful of the liquid levels in the holding tanks. To prevent overflow, they should be emptied as often as possible, especially in cases where the display station has been in continuous use for a long period of time and additional ice has been added to maintain the display.



Care and Cleaning



WARNING

For your safety, the information in the manual must be followed to minimize the risk of fire, explosion, electrical shock or to prevent property damage, personal injury or loss of life. **DISCONNECT ALL POWER TO UNIT BEFORE CLEANING PROCEDURES ARE PERFORMED!**

Quartz Composite Top Surface

- ◆ As a natural stone product, your countertop is subject to damage from thermal shock if exposed to rapid temperature changes. Avoid placing hot pans directly on the countertop surface. Always place hot pans on a trivet, rack or other suitable cooling surface.
- ◆ To clean your countertop and protect its polished finish, we recommend you use a mild household cleaner, such as 409®, Fantastik®, Lysol®, or Windex®. In the case of stubborn spills or stains, soak the area for up to 10 minutes with one of the above cleaners and vigorously wipe away with a non scratch Scotch Brite® pad.
- ◆ **CAUTION:** The following will harm your countertop surface: Drano®, Liquid Plumr®, common oven cleaners and floor strippers. **DO NOT** use these or any other similarly harsh chemicals on your top surface.

Induction Heating Surfaces

- ◆ It is recommended to thoroughly clean the glass surfaces prior to using the appliance for the first time. This will help protect the top and make future cleaning easier. Use a good, high quality ceramic top cleaner and multi-purpose, non-scratching cleaning pad. Thoroughly clean the entire surface of any residue.
- ◆ The key to maintaining your cooktop surfaces is to clean after every use. For heavier, burned on residue, a single-edge razor blade scraper may be used to remove tougher spills. Afterwards, continue with normal cleaning procedures with a high quality ceramic top cleaner and multi-purpose, non-scratching cleaning pad.
- ◆ In most cases, allow the heating surface to completely cool before cleaning. The exception to this rule are spills of foods with a high sugar content or melted plastic which may cause permanent damage to the glass top. In these cases, immediately turn off the appliance. Wearing an oven mitt and using a scraper, immediately remove as much of the spill as possible. Allow the cooktop to completely cool and proceed with removing all remaining residue.

Food & Beverage Display Stations with Ice Bins

- ◆ Thoroughly empty and wipe clean the inner chamber of the glass ice display. It is not recommended to flush the ice display with large amounts of water to clean as this may cause drain obstruction and/or back pressure that may force water to leak into the inner cabinet causing internal damage. The glass display is very heavy. It is recommended that a minimum of two people are utilized to remove the glass display to access the inner cabinet for cleaning.
- ◆ Remove the inner plastic liner tray and thoroughly wipe clean. Make sure the inner liner tray is clean and dry before replacing.
- ◆ Wipe clean the inner stainless steel chamber of any condensation or other spills. Before re-assembly make sure all drain orifices are clear and unobstructed.

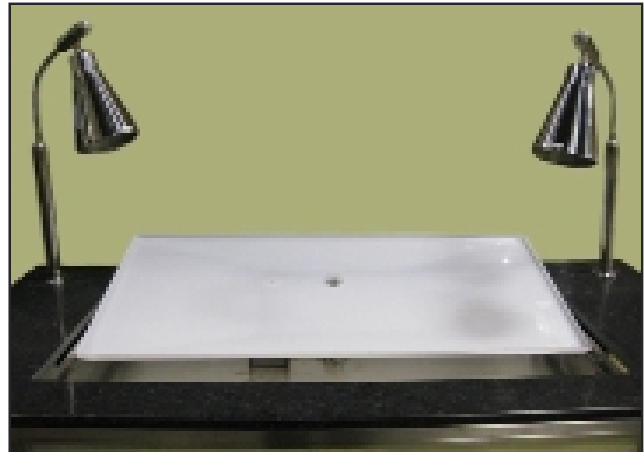

Carving Stations with Heated Carving Tray

- ◆ The carving tray may be cleaned by hand without disconnecting it entirely from the unit. In most cases, it will be required to detach the heating element from the carving tray allowing it to be completely removed from the unit for proper cleaning. Remove the heating element by unscrewing the two M8 wingnuts holding the element to the bottom surface of the tray.
- ◆ Empty all water from the carving tray. The tray may be hand washed or run through a commercial washer. The cutting/carving board is also commercial dishwasher safe. Make sure all components are thoroughly clean and dry prior re-assembly of the carving tray.
- ◆ The heating element must be cleaned by hand. DO NOT immerse the heating element in water. Again, make sure all components are thoroughly clean and dry prior re-assembly and use.



Troubleshooting Guide

Before you call service...

Induction Surfaces:

Problem: Display is black. No Power.	Symptom / Cause: Unit unplugged. breaker tripped.	What to do: Ensure all power sources are functional. Check all breakers.
Problem: Flashing "U"	Symptom / Cause: Missing or unsuitable cookware.	What to do: Ensure cookware is of suitable material and size.
Problem: Flashing "1"	Symptom / Cause: Abnormal supply current.	What to do: Disconnect power from unit and retest. If problem persists, contact Customer Care immediately.
Problem: Flashing "2"	Symptom / Cause: Abnormal supply voltage below 85VAC.	What to do: Check line voltage.
Problem: Flashing "3"	Symptom / Cause: Abnormal supply voltage below 85VAC.	What to do: Check line voltage.
Problem: Flashing "4"	Symptom / Cause: Overheating or thermal overload.	What to do: Check if fan is operational or if ventilation grill is obstructed.
Problem: Flashing "5"	Symptom / Cause: Internal hardware error.	What to do: Contact Customer Care immediately.
Problem: Flashing "6"	Symptom / Cause: Over-heated cookware.	What to do: Ensure cookware is not empty or boiled dry.
Problem: Flashing "7"	Symptom / Cause: Fluctuation in supply power frequency.	What to do: Resume after power frequency stabilizes.
Problem: Flashing "8 or 9"	Symptom / Cause: Internal hardware error.	What to do: Contact Customer Care immediately.



Troubleshooting Guide

Before you call service...

HotPlate Surfaces:

<i>Problem:</i> Unit temperature is high	<i>Symptom / Cause:</i> Thermostat control set too high. Thermostat control stuck in the "ON" position. Unit plugged into an incorrect power supply.	<i>What to do:</i> Adjust thermostat control to a lower setting. Contact Customer Care immediately. Have a certified technician verify power specifications match unit requirements.
<i>Problem:</i> Unit temperature is low	<i>Symptom / Cause:</i> Thermostat control set too low. Location is susceptible to air currents (air conditioning ducts or exhaust fans)	<i>What to do:</i> Adjust thermostat control to a higher setting. Redirect air currents or relocate unit.
<i>Problem:</i> Unit is non-functional	<i>Symptom / Cause:</i> No power to unit Power switch not functioning. Heating Element is burned out or Thermostat control is defective.	<i>What to do:</i> Verify power sources. Breakers are not tripped and unit is on. Contact Customer Care immediately.

General:

<i>Problem:</i> Display or Heatlamp Lighting not working or flickering.	<i>Symptom / Cause:</i> No power to unit, non-secure plug connections, defective bulbs. Bulbs not securely screwed in sockets.	<i>What to do:</i> Verify power sources, that breakers are not tripped and unit is on. Replace or tighten bulbs in fixtures.
<i>Problem:</i> LED lighting not working or sections of unit not lit.	<i>Symptom / Cause:</i> No power to unit. Defective controller unit or power supply. Burned out LED nodes.	<i>What to do:</i> Verify power sources, that breakers are not tripped and unit is on. If problems persist, contact Customer Care immediately.



Warranty Information

DECO Buffet Station Series Warranty

SICO America, Inc., Minneapolis, Minnesota fully warrants the DECO Buffet Station series to be free from defect in materials and workmanship for a period of 1-year from the date of delivery, with the following exception. Due to the nature of the composite top, the top is not covered under the 1-year warranty period. Product defects arising from faulty materials or substandard workmanship will be, at the sole discretion of SICO AMERICA, replaced or repaired to a serviceable condition free of charge to the original purchaser for said 1-year period. The foregoing is SICO's exclusive warranty with respect to the products purchased. SICO MAKES NO WARRANTIES OF MERCHANTABILITY OR FITNESS FOR PURPOSE, and makes no other warranties except for the warranties expressly set forth above.

All repairs and returns must be approved, in writing, by the factory before action is taken. All claims are to be reported to:

SICO America, Inc.
Attn: Customer Care Center
7525 Cahill Road
Minneapolis, MN 55439

The product serial number will be required to process and authorize any warranty claim.

Repair or replacement in accordance with the foregoing procedure is the buyer's sole and exclusive remedy for any defective products, whether buyer's claim arises under contract, tort or otherwise. SICO shall not be liable for any consequential damages, and in any event, SICO's liability is limited to the purchase price paid for the products purchased.



Service Information

SERVICE:

- ♦ Customer Care Center: 1-800-424-0796
- ♦ Website: www.sicoinc.com
- ♦ Email Address: customercare@sicoinc.com
- ♦ Written correspondence:
SICO America Incorporated
Attn: Customer Care Center
7525 Cahill Road
Edina, MN 55439-2745
- ♦ When requesting information, literature, replacement parts or service, *always refer to the model number and serial number of your unit.* This information is found on the rating plate located on the inner wall of the storage cabinet near the central power center.
- ♦ Record all the rating plate information here or on the front page of this manual for future reference.

Model Number: _____

Serial Number: _____

Purchase Date: _____

REGARDING THE WARRANTY:

This equipment and/or the components contained therein are design certified by various, nationally recognized, testing laboratories to the appropriate national standards as indicated on the individual components model/serial rating plate. ANY modification to this equipment or any components contained therein without written permission from SICO America Incorporated® voids any certifications and warranty of this product.

BEFORE CALLING SERVICE:

- ♦ Refer to the troubleshooting guide on pages 18-19.
- ♦ For electrical issues, double check to ensure proper electrical connection to the unit. Check circuit breakers are not tripped or defective. Outlet receptacles are proper working order or the possibility of a power outage.
- ♦ For warranty purposes, have your model, serial number and date of purchase before contacting the SICO Customer Care Center.

SHIPPING DAMAGE CLAIMS:

This product contained in this shipment was packaged in accordance with stringent standards and inspected before leaving the factory. All products should be inspected immediately upon receipt to insure damage is discovered and noted on the delivery receipt. Any concealed damage must be reported to the carrier within 15 days of delivery. All damage claims must be filed directly with the carrier.

SICO America Incorporated® does not assume responsibility for damage or loss incurred in transit. However, we will be more than happy to furnish you with any documents necessary to support your claims.