

**TO ATTACH STAGES**

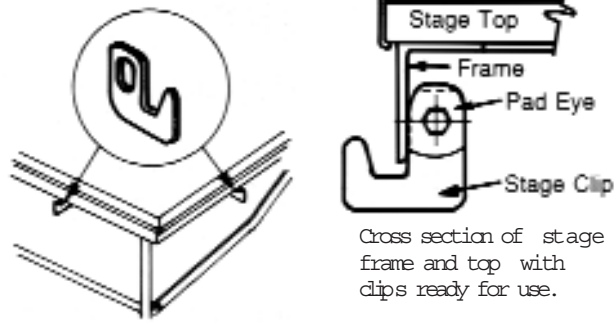

Cross section of stage frame and top with clips ready for use.

All SICO stages are provided with 3 stage clips to attach one stage to another of the same height.

Clips can be easily relocated to any of all six sides of stage by removing 1 bolt and nut.

When clips are placed on the same side of swivel casters, it is easier to hook stages together.

For shipment convenience stage clips are installed rotated in 90°. To be used, clips should be rotated outward past frame.

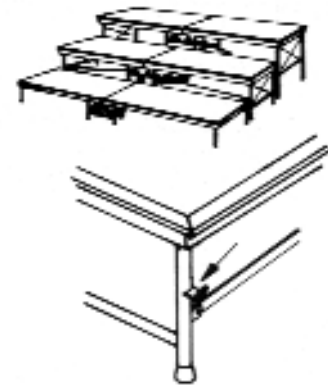

Stages are provided with dual height clips on each end leg, for setting stages up in a choral-riser fashion.

Lower stages can be secured to higher stages by inserting frames onto clips. Safe multi-level staging is obtained this way.

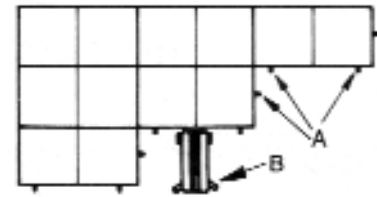

Views shows several stages already attached to each other. Notice assembly starts from the left rear. The folded stage should be positioned in front, and next to, open stage, ready to be received by stage clips (A). Keep swivel casters (B) away from open stages.

When using choral-riser staging assembly is the same, only position folded stage approximately 6 to 8 from open stages.

**STEPS**

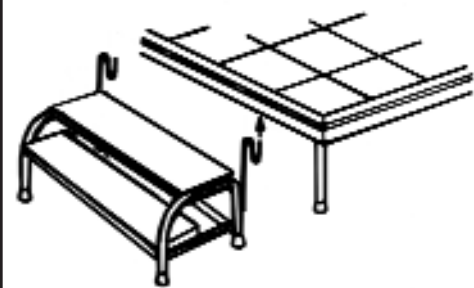

Steps hooks (which catch against stage frame) are designed to attach to a stage the same height as top step or a stage 8" higher.

Drapes can still be used along with steps

**CORNER SECTIONS**

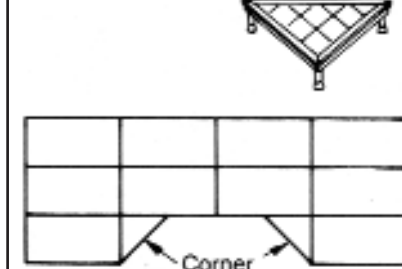

Triangular corner sections, 8" high, are placed at the inside corners. Stage clips on stages (see top page 2) are used to fix corner sections to stages.

**Guardrails**

To Set-Up Guardrail for use:

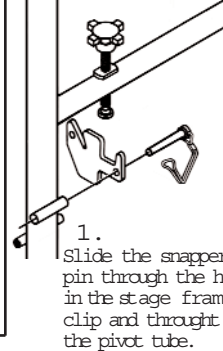

1. Slide the snapper pin through the hole in the stage frame clip and through the pivot tube.

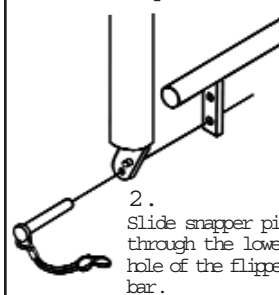

2. Slide snapper pin through the lower hole of the flipper bar.

Guardrails should be used on all stage set-ups

To Install Guardrail:

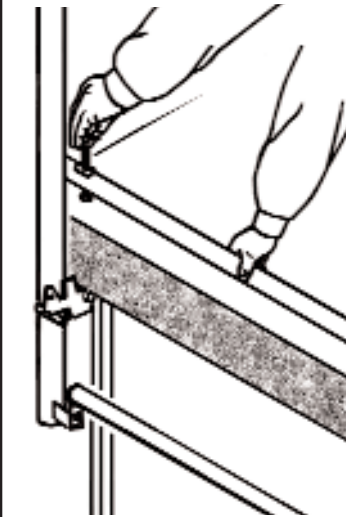

Attach guardrail by hooking the two stage frame clips under and behind the stage frame. Tighten top adjustable clamp until the guardrail is tight against the deck.

**CHAIR / TABLE TO P COMBINATION**



Chair stops are attached to the stage by tightening socket head screws against the frame. Chair stops must be removed before folding stage.



SICO AMERICA, INC. 7525 Cahill Road / Minneapolis, MN 55439 U.S.A.  
Call toll free 1-800-424-0796 or Fax 1-952-829-5141 / www.sicoinc.com

1800 STAGE OPERATING INSTRUCTIONS  
INSTRUCCIONES DE OPERACION PARA LAS PLATAFORMAS SICO 1800

**WARNING**

IMPROPER HANDLING OF THIS UNIT COULD CAUSE IT TO FALL, WHICH COULD RESULT IN SERIOUS INJURY. BE SURE TO READ AND UNDERSTAND THE OPERATING INSTRUCTIONS BEFORE OPERATING THIS UNIT. DO NOT ALLOW CHILDREN OR UNTRAINED PERSONS TO OPERATE THIS UNIT.

Use caution and care for your back when lifting, pushing, pulling or folding and unfolding these units. Never lift more than you can safely handle.

Guardrails should be used on all stage set-ups

**AVISO**

EL MANEJO INCORRECTO PUEDE CAUSAR LA CAIDA DE ESTA UNIDAD LO QUE PROVOCARÁ DAÑOS SERIOS. LEA CON ATENCIÓN Y ENTIENDA LAS INSTRUCCIONES DE OPERACION ANTES DE MANEJAR ESTA UNIDAD. NO PERMITA QUE NI NIÑOS O PERSONAS SIN ENTRENAMIENTO OPEREN ESTA UNIDAD.

Tenga mucha precaución y cuidado con su espalda cuando levante, empuje, jale o pliegue estas plataformas. Nunca levante más peso del que sea necesario para hacerlo en forma segura.

Los rieles protectores deben ser usados en el armado de la plataforma.

**MAINTENANCE:** Lubricate pivot points every six months.

**Mantenimiento:** Lubrique los puntos del pivote cada 6 meses.

INTERLOCK HOOKS MUST BE USED LOS GANCHOS PARA ENTRELAZAR DEBEN SER USADOS



VIEW UNDER STAGE VISTA PRO DABAJO DE LA PLATAFORMA

Each stage is shipped with three interlock hooks that must be turned outward. After first stage is set - each additional open stage is positioned so the sides and ends lock onto the extended hooks.

**MOVING THE STAGE UNIT**  
**TRANSPORTE DE LA PLATAFORMA**

Push only from swivel (yellow) end of unit.

Empuje solamente desde el extremo del bloque (amarillo) con ruedas.

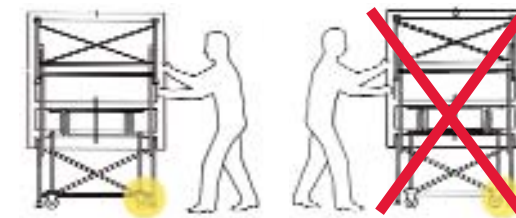

**UNFOLDING THE STAGE UNIT**  
**DESPLIEGADO DE LA PLATAFORMA**

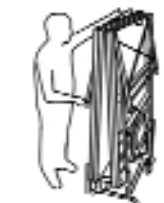

1. Release safety strap on top edge of unit. Desprenda la correa de seguridad en la parte superior de la plataforma.



3. Pull smoothly towards you to start the unfolding action. Lower first half of unit to floor. Lentamente comienza a jalar para comenzar la acción de despliegado. Baje al piso la primera mitad de la plataforma.



2. Standing at the center, grasp top edge of stage deck with one hand, and leg cross-brace with other hand. Pull out on leg to unlock. Parado en el centro de la plataforma, agarre con una mano la parte superior de la cubierta de la plataforma y con la otra agarre la barra conectora en forma de cruz de las patas. Jale de una pata para abrirla.

**DO NOT PULL OR PUSH**  
**NO JALE O EMPUJE**

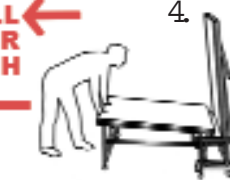

4. Do not pull or push with unit half open. No jale o empuje con la plataforma medio abierta

5. Repeat operation for second half of unit. Repita el procedimiento para la segunda mitad.

**FOLDING THE STAGE UNIT FOR STORAGE**  
**PLEGADO DE LA PLATAFORMA PARA GUARDARLA**



1. Standing at the center, lift either end smoothly to fold. Parado en el centro, levante lentamente cualquiera de las dos mitades de la plataforma para plegarla.



2. Continue folding until half of unit is slightly past vertical. Push leg in to relock. Continúe el plegado hasta que la mitad de la plataforma pase ligeramente de la posición vertical. Empuje la pata para asegurarla.

3. Now stand at center of other end. Ahora, póngase en el centro de la otra mitad de la plataforma.



4. Lift smoothly to repeat folding action. Levante lentamente para repetir el plegado.



5. Continue folding until second half of unit is also slightly past vertical. Continúe el plegado hasta que la segunda mitad de la plataforma también pase ligeramente de la posición vertical.

6. Push leg in to relock. Rehook strap. Unit is now fully folded ready for storage. Empuje la pata en el seguro. Enganche la correa de seguridad. Ahora la plataforma está plegada completamente y lista para ser guardada.

SICO Incorporated reserves the right to substitute materials or make changes if materials are not available and such changes improve the product.

Visit our website at [www.sicoinc.com](http://www.sicoinc.com)

The Americans  
SICO America Inc.  
USA  
In U.S., phone (800) 328-6138  
Outside U.S., (952) 941-1700  
Fax: (952) 941-6688  
E-mail: [sales@sicoinc.com](mailto:sales@sicoinc.com)

Europe  
SICO Europe LTD.  
England  
Phone [44] (1303) 234000  
Fax: [44] (1303) 234001  
E-mail: [sales@sicoeurope.com](mailto:sales@sicoeurope.com)

Spain & Portugal  
Sistemas SICO S.L.  
Spain  
Phone [34] (91) 358-9076  
Fax: [34] (91) 358-9264  
E-mail: [sales@sistemas-sico.com](mailto:sales@sistemas-sico.com)

Australasia & South Africa  
SICO South Pacific  
Australia  
Phone [61] (2) 4388-5100  
Fax: [61] (2) 4389-1341  
E-mail: [sales@sicosp.com.au](mailto:sales@sicosp.com.au)

Japan  
SICO Nippon Co., LTD  
Japan  
Phone [81] (3) 3791-2277  
Fax: [81] (3) 3791-3300  
E-mail: [siconpn@apricot.ocn.ne.jp](mailto:siconpn@apricot.ocn.ne.jp)

Asean Countries/  
Korea & India  
SICO Asia PTE LTD.  
Singapore 118535  
Phone [65] 6472-2633  
Fax: [65] 6472-2600  
E-mail: [sales@sicoasia.com](mailto:sales@sicoasia.com)

China  
SICO-SST  
China  
Phone [86] (10) 6467-9126  
Fax: [86] (10) 6466-4815  
E-mail: [sales@sico-sst.com](mailto:sales@sico-sst.com)

**MAINTENANCE**

Tuffdeck decks: Wash with soap and water. Use vinyl floor wax. Do not let water stand on decks.

Banding: Scratch marks may be painted.

Pivot Points: Lube pivot points every 6 months.

# INSTRUCTIONS FOR ADJUSTING STAGE HEIGHT INSTRUCCIONES PARA EL AJUSTE DE LA ALTURA DE LA PLATAFORMA

## ADJUSTING THE STAGE UNIT TO NEXT HEIGHT    AJUSTE DE LA ALTURA DE LA PLATAFORMA

**1** Before unfolding legs, pull out pins from end of legs.  
Antes de desplegar las patas, quite los pemos de los extremos de las patas.



**2** Pull out telescoping legs to next height.  
Extienda las patas hasta la altura siguiente.

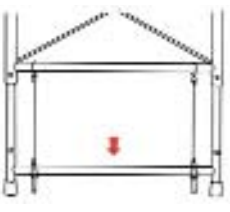

REPEAT THESE STEPS ON OPPOSITE SIDE OF UNIT.  
REPITA ESTOS PASOS EN EL EXTREMO OPUESTO DE LA PLATAFORMA.

**3** Replace pins completely through the legs.  
Vuelva a colocar los pemos atraves de los extremos de las patas.



**4** Undo straps and fold out center legs. Make sure legs are completely unfolded.  
Desprenda la correa y despliegue las patas. Asegere que las patas estAn desplegadas completamente.

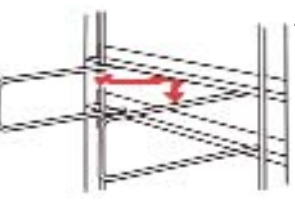

## UNFOLDING EXTENDED HEIGHT UNIT FOR USE

**1** Release safety strap on top edge of unit.  
Desprenda la correa de seguridad de la parte superior de la plataforma.

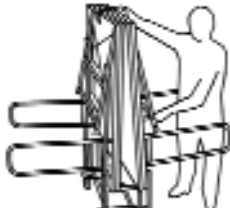

**2** Standing at center, pull out on upper leg to unlock, then lower half of unit until legs touch the floor.  
Parado en el centro, jale la pata superior para abrir, luego baje la mitad de la plataforma hasta que las patas toquen el piso.

**DO NOT PULL OR PUSH**  
**NO JALE O EMPUJE**

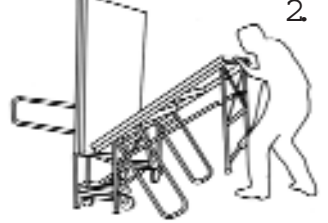

**3** Release safety strap on top edge of unit.  
Ahora baje la otra mitad de la plataforma hasta que las patas centrales toquen el piso.



**4** Push downward on end of stage until unit slides into open position with legs solidly on the floor. Make sure the center legs are vertical.  
Empuje hacia abajo del extremo de la plataforma hasta que quede en la posición abierta con las patas firmes en el piso. Asegere que las patas centrales estAn verticales.

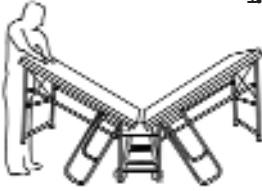

## FOLDING EXTENDED HEIGHT UNIT FOR STORAGE PLEGADO DE LA PLATAFORMA CON ALTURA EXTENDIDA PARA GUARDARLA

**1** Standing at the center, lift either end until it is slightly past vertical. Do not let go of unit. Push in leg to relock.  
Parado en el centro de la plataforma, levante cualquiera de los dos extremos hasta que pase ligeramente de la posición vertical. Mantenga contacto con la plataforma. Empuje la pata para asegurarla.



**2** While holding end of unit in the vertical position, grasp center leg and pull smoothly towards yourself.  
Mientras tiene agarrado el extremo de la plataforma en la posición vertical, agarre la pata central y lentamente jale la pata hacia su cuerpo.



**3** Continue pulling smoothly until the folding action sets all four casters on the floor, and the raised end will stay vertical without assistance.  
Continue jalando lentamente hasta que la acción de plegado coloque los cuatro bloques con ruedas en el piso y el extremo levantado permanezca vertical sin ayuda.

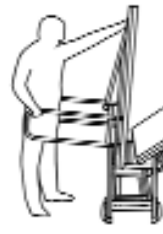

**4** Standing at the center of the second side, lift smoothly to fold this half vertical. Push in leg to relock.  
Parado en el centro de la segunda mitad de la plataforma, levántela suavemente para plegar verticalmente esta mitad. Empuje la pata para asegurarla.

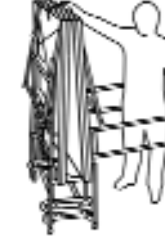
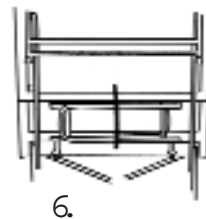

**5** Rehook top safety strap, then fold in remaining center legs and strap into place.  
Enganche nuevamente la correa superior de seguridad, luego pliegue el resto de las patas centrales y asegere las en su lugar.

## 16 THRU 40 HIGH STAGE ASSEMBLY - 3, 4 AND 6 WIDE X 8 LONG MOBILE FOLDING STAGES

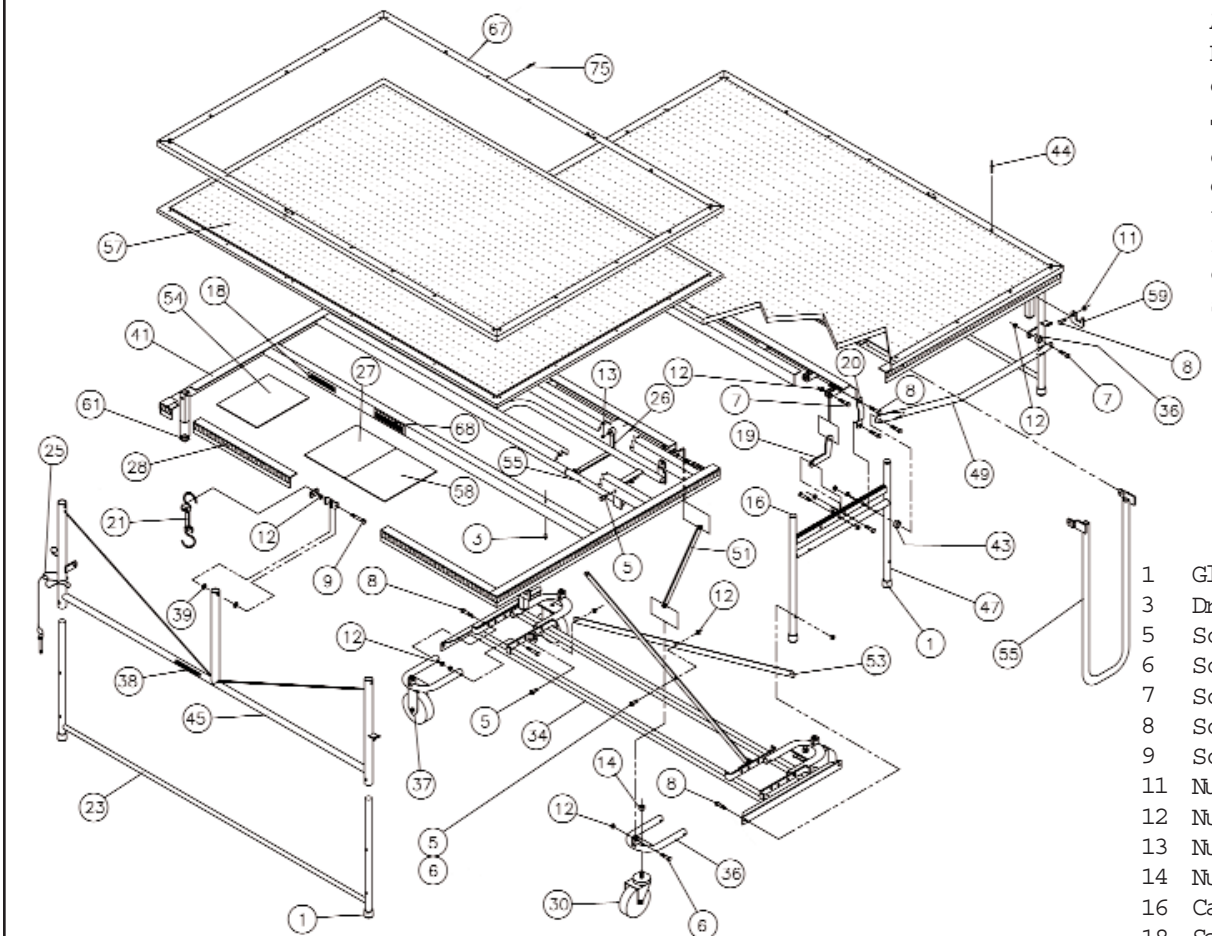

Always include the Serial Number of the stage when ordering parts  
The serial number is located inside the steel frame, on the lower part of one of the decks. When stage is folded, serial number is clearly visible on lower section of the steel frame.

- 1 Glide Cap Round 1.00
- 3 Drive Rivet .25 x .53
- 5 Screw, C HH .38-24 x 1.00
- 6 Screw, C HH .38-24 x 1.25
- 7 Screw, C HH .38-24 x 1.50
- 8 Screw, C HH .38-24 x 1.75
- 9 Screw, C HH .38-24 x 2.50
- 11 Nut .38-24
- 12 Nut Stop .38-24
- 13 Nut .25-20
- 14 Nut Stop .50-13
- 16 Cap Tube Round 1.0 x .83
- 18 Serial Plate
- 19 Link Connector
- 20 Bar Connector
- 21 Strap 4-in. rubber
- 23 Weld, End Extension
- 25 Assembly Wire Hitch Pin
- 26 Assembly Strap
- 27 Label Instructions Stage
- 28 Velcro Hook 1.00
- 30 5-in. Swivel Caster
- 34 Caster Frame
- 35 Instructions Stage Warning
- 36 Weld Caster Beam
- 37 Caster Beam
- 38 Label Stage Warning
- 39 Washer 3/8 SAE
- 41 Weld Top Frame
- 43 Spacer .50 x .50
- 44 Rivet, Alum Blind .188
- 45 Weld, Upper Leg
- 49 Bar Tension
- 51 Lever Top Frame
- 52 Assembly Leg 8
- 53 Sway Brace
- 54 Label Stage 1800
- 55 Leg Center 1800
- 57 Deck Assembly
- 58 Label Instructions Stage
- 59 Clip - Unit to Unit
- 61 Plug Square .88 x 16ga.
- 65 Rivet Blind .19 x .38
- 67 Banding Edge
- 68 Label Stage Warning
- 73 Screw, C HH .38-24 x 2.00
- 74 Screw, C HH .38-24 x 2.25

## 8 HIGH STAGE ASSEMBLY

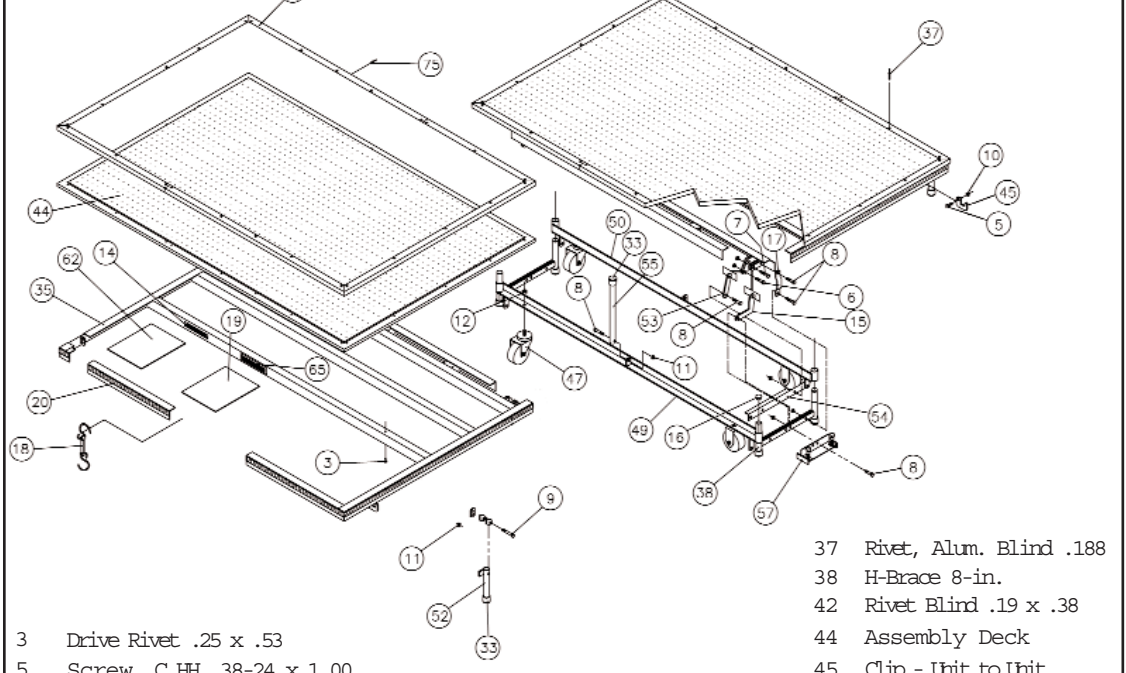

- 3 Drive Rivet .25 x .53
- 5 Screw, C HH .38-24 x 1.00
- 6 Screw, C HH .38-24 x 1.25
- 7 Screw, C HH .38-24 x 1.50
- 8 Screw, C HH .38-24 x 1.75
- 9 Screw, C HH .38-24 x 2.50
- 10 Nut .38-24
- 11 Nut .38-24
- 12 Nut Stop .50-13
- 14 Serial Plate
- 15 Link Connector
- 16 Cap Tube Round 1.0x.083
- 17 Bar Connector
- 18 Strap 4-in. Rubber
- 19 Label Instructions Stage
- 20 Velcro Hook 1.00
- 27 Instructions Stage
- 33 Glide Cap Round 1.00
- 35 Weld Top Frame
- 37 Rivet, Alum. Blind .188
- 38 H-Brace 8-in.
- 42 Rivet Blind .19 x .38
- 44 Assembly Deck
- 45 Clip - Unit to Unit
- 47 4-in. Swivel Caster
- 49 Beam Caster LH
- 50 Beam Caster RH
- 52 Assembly Leg 8
- 53 Lever Top Frame
- 54 Label Stage
- 57 Deck Assembly
- 58 Label Instructions Stage
- 62 Label Stage
- 63 Edge Banding
- 65 Label Stage Warning
- 75 Rivet Blind .188