



SICO AMERICA INC.
7525 Cahill Road
Minneapolis, MN 55439, USA
Customer Service: 1-800-424-0796
Website: www.sicoinc.com

2800 TABLE

Operating Instructions and Parts List

Folded for storage.
Plegada para guardaria.

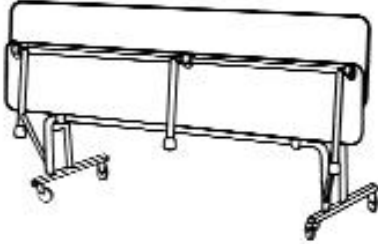

Used as seat with backrest
Como asiento con respaldo.

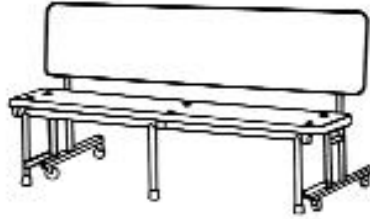

Used as table with bench.
Como mesa con banco.

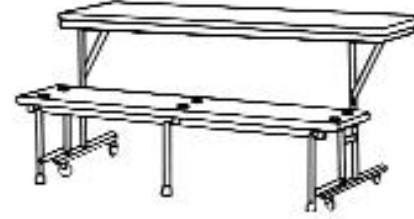

TO BE USED AS SEAT AND BACKREST:

PARA USARLA COMO ASIENTO CON RESPALDO:

①



Grasp seat at the center.
Tome el asiento por el centro.

②



Rotate seat down.
Empuje el asiento hacia abajo.

③

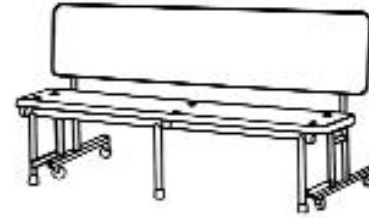

Seat with backrest is ready.
El asiento con respaldo está listo.

TO BE USED AS TABLE WITH BENCH:

PARA USAR COMO MESA CON BANCO:

①



Grasp the backrest at lower center.
Tome el respaldo por la parte inferior del centro.

②

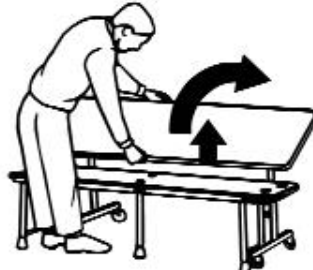

Pull up and rotate backwards.
Tire hacia arriba y gire hacia atrás.

③

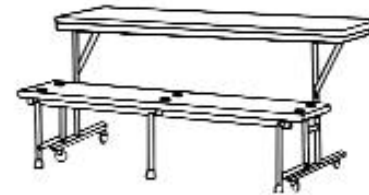

Push away from you until the top locks.
Empuje alejándola de usted hasta que la tapa quede fijada en su lugar.

TO UNLOCK TOP:

PARA DESTRABAR LA TAPA

①

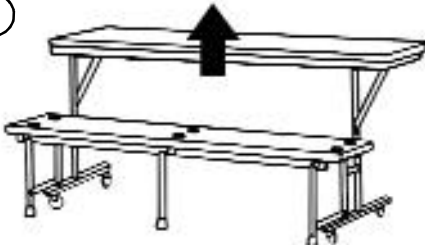

Pull up top, vertically, about 1/2 inch.
Tire la tapa hacia arriba, en forma vertical, aproximadamente 1,27cm.

②

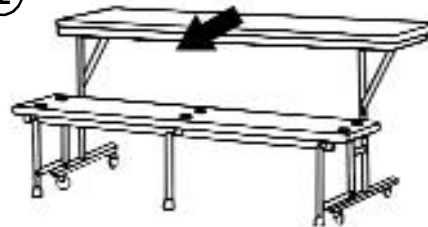

Pull toward you horizontally.
Tire hacia usted en forma horizontal.

③



Rotate top down.
Empuje la tapa hacia abajo.

NOTE: DO NOT tighten bolts and nuts at pivot points and slides.
Maintenance: Lubricate pivot points twice a year.

Nota: NO AJUSTE los tornillos y las tuercas en los puntos basculantes ni en los deslizadores.
Mantenimiento: Lubrique los puntos basculantes dos veces al año.

IMPORTANT:

Please include Serial Number of table when ordering parts.

IMPORTANTE:

Incluya el Número de Serie de la mesa cuando ordene piezas.

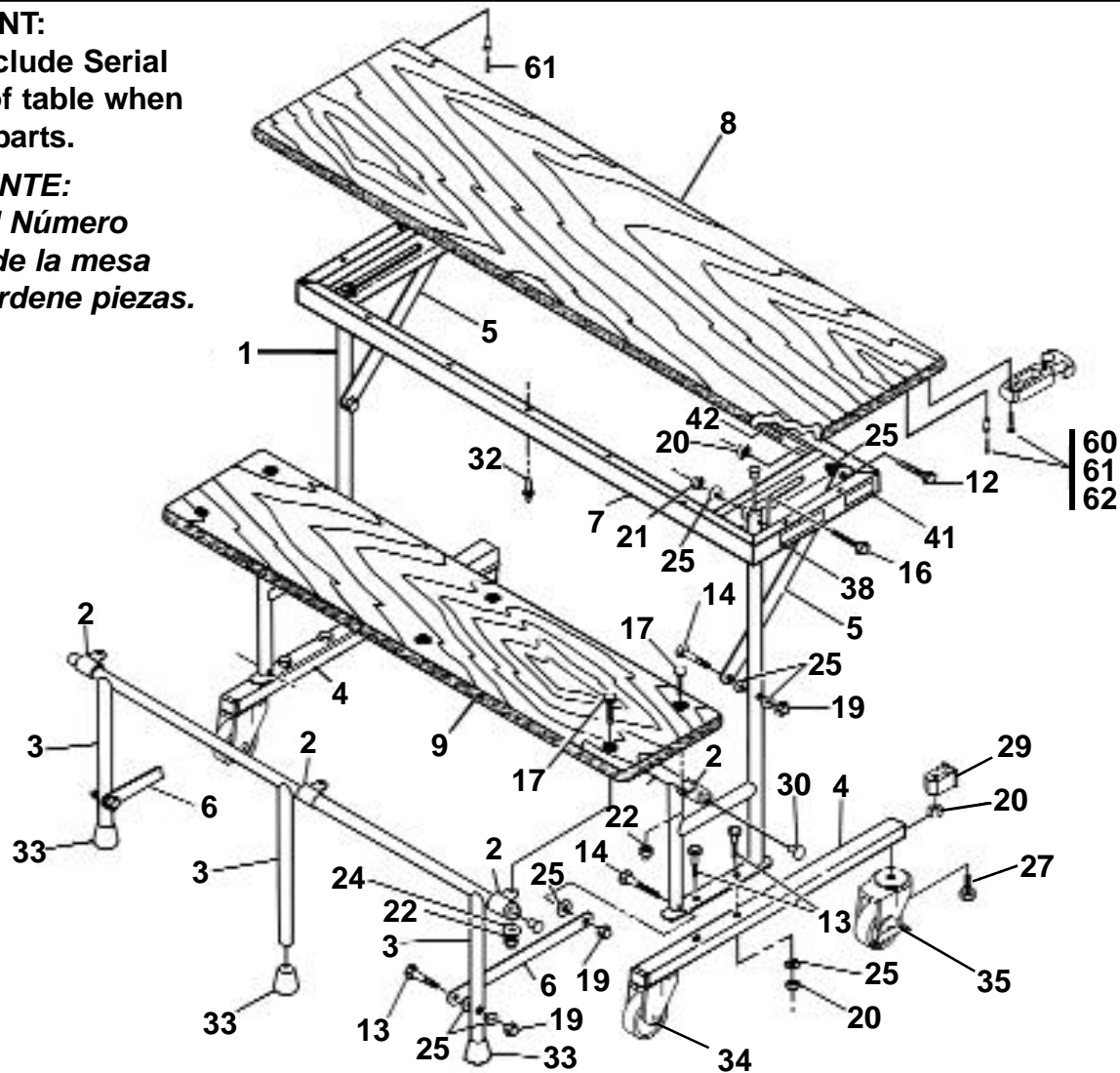

SICO MODEL 2800 CONVERTIBLE BENCH TABLE

Models 2800-627, 2800-727, 2800-827, 2800-629, 2800-729, 2800-829

Component Parts List

Ref. No.	Description	Ref. No.	Description	Ref. No.	Description
1	Chassis Weldment (6'x27")	7	Top Frame Weldment (7')	24	Washer L Internal .31
1	Chassis Weldment (6'x29")	7	Top Frame Weldment (8')	25	Washer FL .41x.82x.06
1	Chassis Weldment (7'x27")	8	Top (6')	27	Screw CHH M10x1.5x25mm
1	Chassis Weldment (7'x29")	8	Top (7')	29	Square Tube Caplug 1"
1	Chassis Weldment (8'x27")	8	Top (8')	30	Plug Round 1.25x14ga.
1	Chassis Weldment (8'x29")	9	Bench (6')	32	Rivet Drive .25x.53
2	Pivot Weldment	9	Bench (7')	33	1" Glide, Black
3	Leg Weldment (6'x27")	9	Bench (8')	34	3" Swivel Caster
3	Leg Weldment (6'x29")	12	3/8-24x1-1/4" Cap Screw	35	3" Swivel Caster (locking)
3	Leg Weldment (7'x27")	13	3/8-24x1-3/4" Cap Screw	38	Serial Plate
3	Leg Weldment (7'x29")	14	3/8-24x2" Cap Screw	41	U.L. Label
3	Leg Weldment (8'x27")	16	3/8-16x2-1/2" Tap Bolt	42	Model Number Label
3	Leg Weldment (8'x29")	17	Weld Screw .31-18x1.25		
4	Caster Beam	19	Nut Jam .38-24	(Optional):	
5	Top Leveler	20	Nut Stop M10x1.5x25mm	60	Flexible Latch Assembly
6	Leg Leveler	21	3/8-16 Stop Nut	61	Keeper Assembly
7	Top Frame Weldment (6')	22	Nut Acorn .31-18	62	Rivet Drive .25x.66