

1 Install drill stop securely onto the drill bit. Set the drill stop at a maximum depth of 45/64" (18mm).

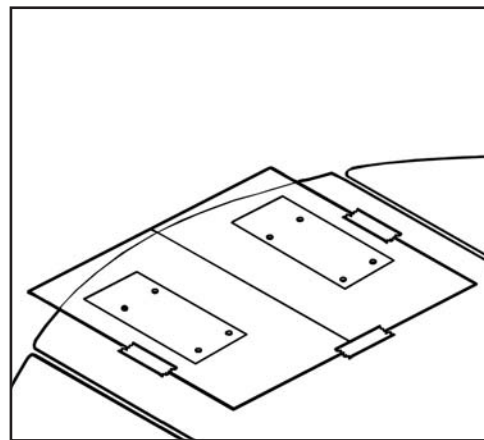

2 Tape template to the bottom of the table top. Be sure to line up the flat edge of the table with the appropriate line of the template.

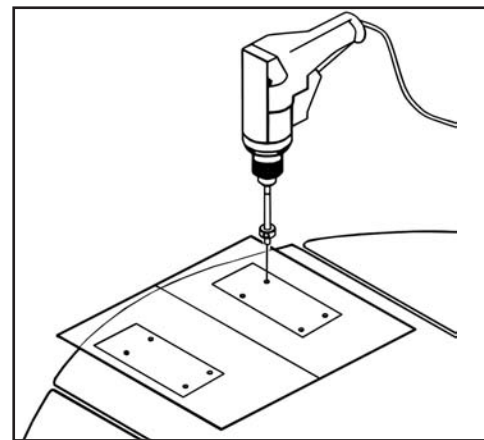

3 Drill holes into the table top in each of the eight locations shown on the template. Use of a center punch can help keep the drill bit centered on the holes.

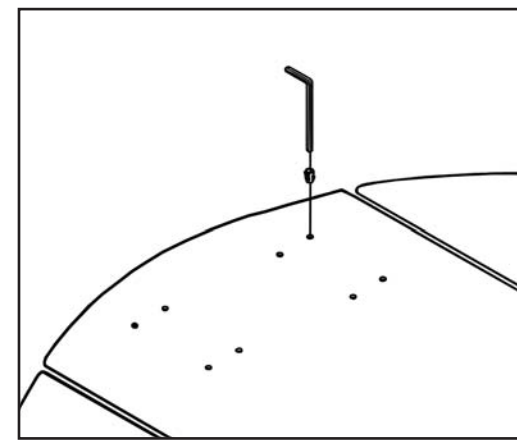

4 Using the Allen Wrench (metric 6mm), screw the insert into the holes. Take care to ensure the insert is flush with the vinyl backer. Clean debris from the holes.

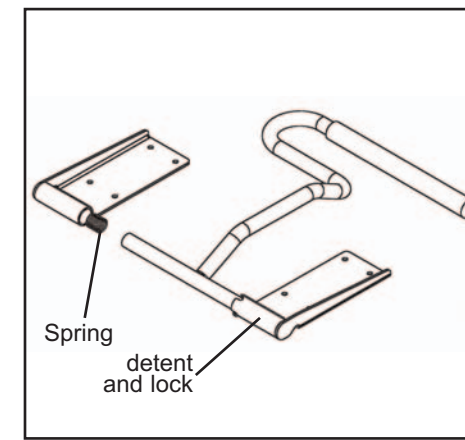

5 Put handle together, making sure the (2) springs are inserted into the side opposite the detent and lock tab.

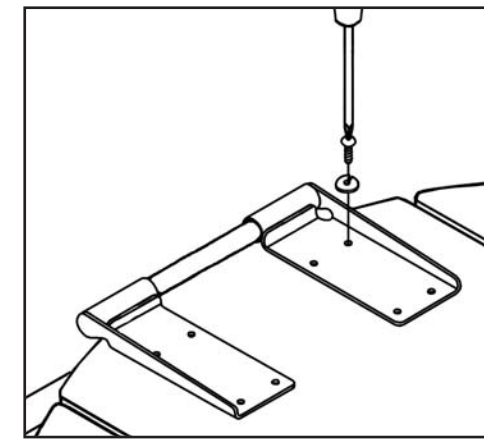

6 Using phillips screw driver, put screws through the lock washer and into the inserts. Verify the handle locks and tighten screws.

TABLE HANDLE RETROFIT TEMPLATE AND INSTRUCTIONS

Tools Required:
 Drill
 Phillips Screwdriver
 Drill stop attachment (included)
 Drill Bit 11/32" (included)
 Allen Wrench (2 included)
 Tape Measure
 Center Punch (recommended)

Note: Attaching the Guide Tool assembly to the table is easier when the table is turned upside down.

READ ALL INSTRUCTIONS BEFORE BEGINNING

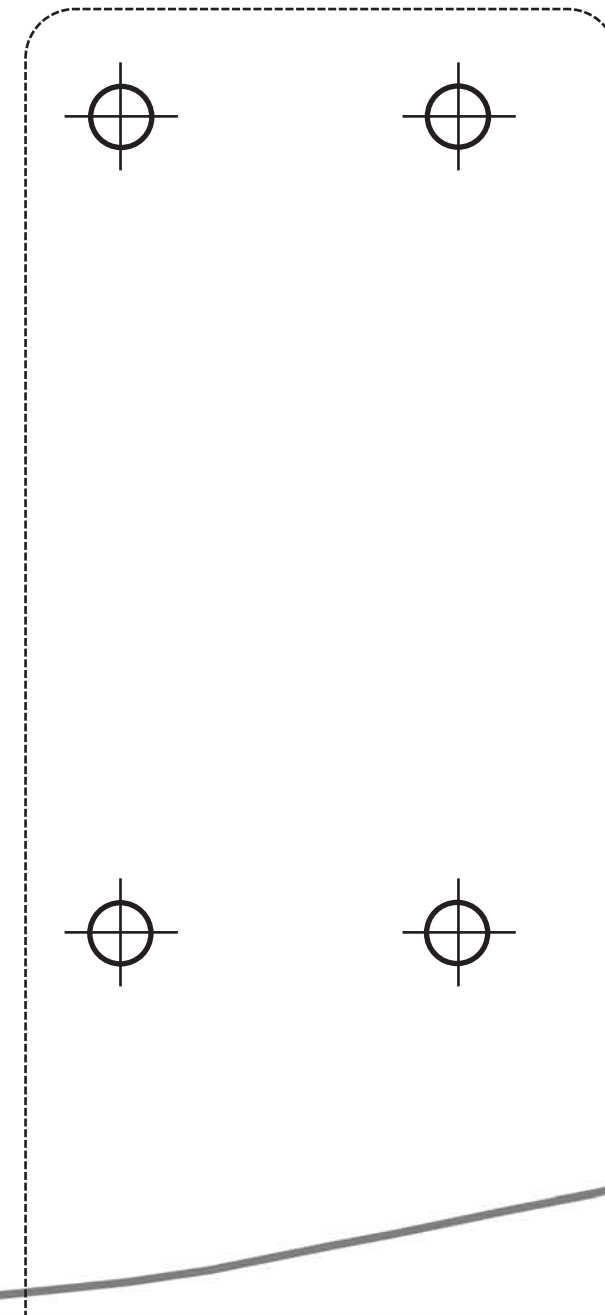
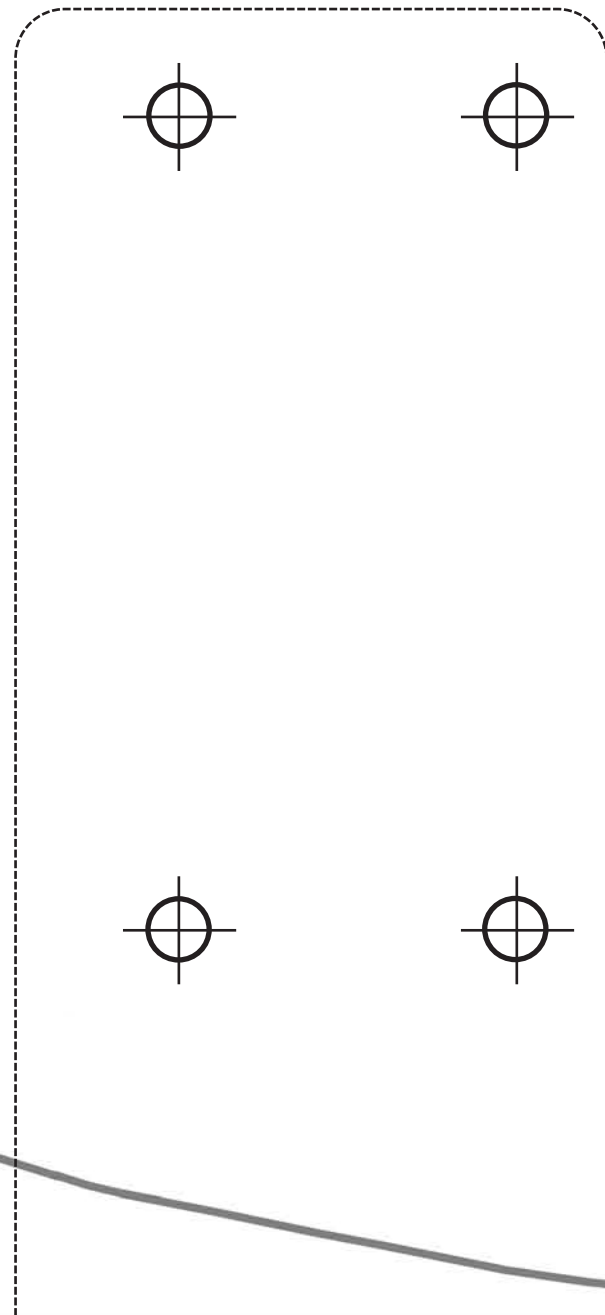

Centerline of Handle

Edge of top