



**EUROBED®**  
(MODEL No. 4182, 5682, 6387)

**and 24/7 EUROBED®**  
(Model No. 5690T, 5695T, 6395T)

## INSTALLATION INSTRUCTIONS

### BEFORE YOU BEGIN...

#### **▲WARNING**

**This bed must be securely anchored to the wall or floor. Failure to follow instructions may cause the bed and cabinet to tip over, which could cause serious injury.**

**NOTICE: It takes *two* people to safely assemble the system - *do not* try to do it by yourself.**

Please read and understand the instructions **before** you start to assemble.

**If you have any problems when installing, contact SICO Customer Service at 1-800-328-6138**

### Tools Required

- Phillips and flat blade screwdrivers
- Electric drill, 1/4" or 3/8"
- Drill bits: 1/8"; 3/16"; 1-3/8" (not required if using SICO recess). A 1" bit may also be required (see page 9).
- Rotary hammer drill (if attaching to floor)
- Masonry bit (if attaching to masonry floor or wall); size of bit depends on floor type - refer to pages 8-10
- Screw-anchor setting tool (if attaching to soft concrete floor)
- Carpenter's Level
- Tape Measure
- Stud finder (preferably an electronic type)
- Hammer
- Ratchet wrench, 9/16" standard and 3/4" deep socket.



### RECESS

LOCATION OF (2) 1-3/8" DIA. X 9/16" DP. HOLES.

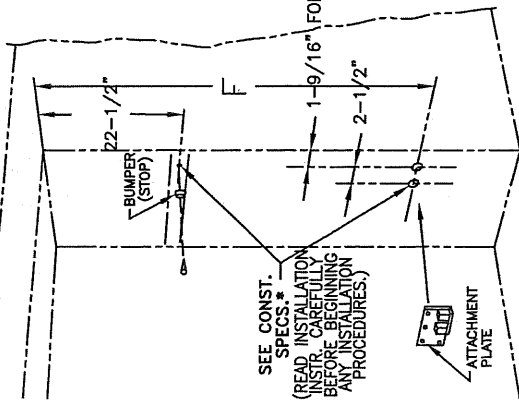

SEE CONST. SPECS.\*  
(READ INSTALLATION INSTR. CAREFULLY BEFORE BEGINNING ANY INSTALLATION PROCEDURES.)

### BED RAISED

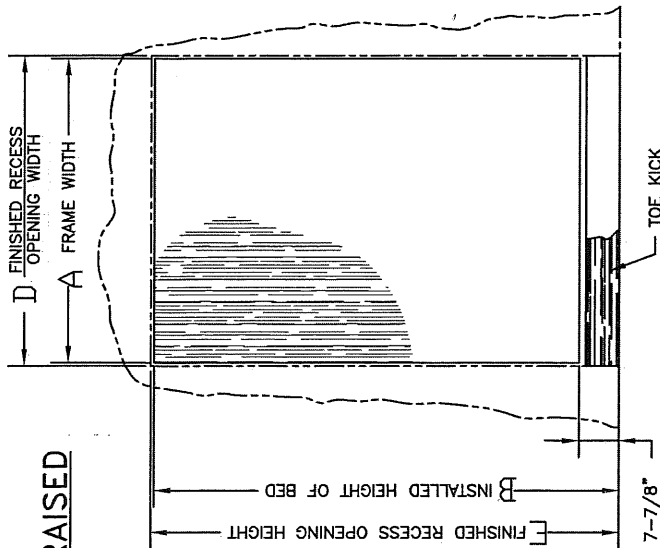

### MATERIAL SPECIFICATIONS:

FRAME : .83 ALUMINUM EXTRUSION  
LEG : 3/4" X 18 GAUGE C.R.E.W. STEEL TUBING  
FLOORPLATE : 3/4" PAINTED PLYWOOD

### CONSTRUCTION SPECIFICATIONS:

THE BED IS AVAILABLE IN THE 3 SIZES CHARTED IN THE MIDDLE OF THIS DRAWING. CEILING HEIGHT MUST BE A MINIMUM 100" FOR DOUBLE XL AND QUEEN SIZES AND 95" MINIMUM FOR DOUBLE SIZE. THE BOTTOM OF THE BED FRAME PROVIDES THE WALL CLOSURE. BED IS SHIPPED WITH NO FACE, 3/8" FINISHED LAMINATE FACE IN CHOICE OF COLORS, OR WITH 3/8" PAINT-READY FACE PANEL.

RECESS MUST BE CONSTRUCTED BEFORE BED IS INSTALLED. SHEETROCK CONSTRUCTION IS NOT ALLOWABLE ALONGSIDE BED FOR SUPPORT. BED MOUNTS INTO A STEEL ATTACHMENT PLATE WHICH IS SECURED TO EACH SIDE OF RECESS. A MINIMUM OF 3/4" PLYWOOD IS REQUIRED FOR ATTACHMENT OF PLATES AND BUMPERS.

TWO PULL HANDLES ARE PROVIDED WITH EACH BED FOR CUSTOMER TO INSTALL, OR THEY MAY USE THEIR OWN HANDLE DESIGN. (2) PILOT HOLES ARE DRILLED ALONG EACH SIDE OF THE FRAME ON 3" CENTERS FOR ATTACHING HANDLES.

ADJUSTMENT BOLTS ALLOW ALIGNMENT IN THE RECESS OPENING AND COMPENSATE FOR THE WEIGHT AND DIFFERENCES IN BED FACES. BED IS SHIPPED IN ONE CARTON.

BED SIZE	BED FACE SIZES					
	A	B	C	D	E	F
DOUBLE	55-1/2"	84-7/8"	68-3/8"	56"	86-3/16"	68-13/16"
DOUBLE XL	55-1/2"	89-7/8"	73-5/16"	56"	91-3/16"	73-13/16"
QUEEN	62"	89-7/8"	73-5/16"	62-1/2"	91-3/16"	73-13/16"

\*(2) FACE PANELS REQUIRED WITH 1/8" GAP BETWEEN PANELS.

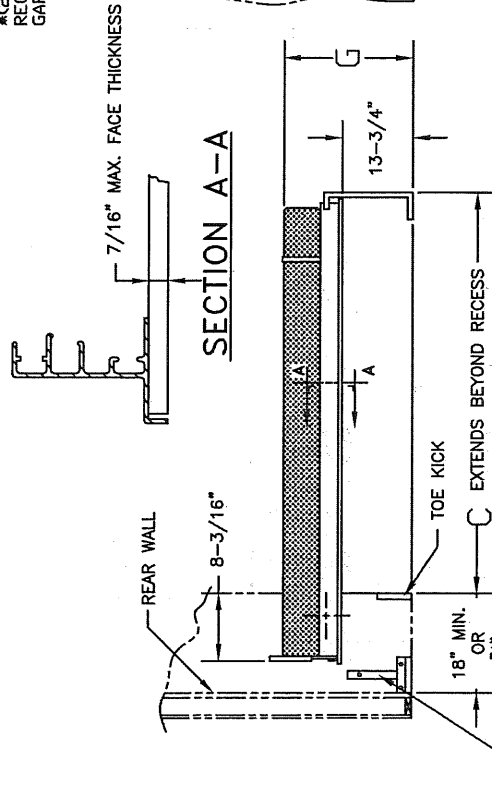

### BED LOWERED

MATTRESS TYPE	G
SILVER CREST	26-3/8" TO 27-3/8"
GOLD CREST	28-3/8" TO 29-3/8"
PLATINUM CREST	28-7/8" TO 29-7/8"

### 24/7 EUROBED WALLBED NUMBER FORMAT

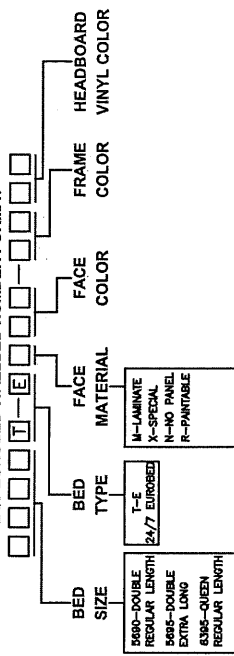

\*BASEPACER (REQUIRED ON FREESTANDING VERTICALS)

## WARNING!

### ▲ WARNING

**If you fail to properly secure the recess to the wall or floor, it could be pulled down and serious injury could result.**

The counterbalancing of the EUROBED® is supported by the weight of the cabinet **plus** the attachment of the cabinets to the wall. It is therefore **very important** that the recess / cabinets system be anchored securely to the wall, as high off the floor as possible. Use the SICO wall-mounting fixture provided with the bed.

If your wall construction is such that the system cannot or should not be attached to the wall (see step 1 on page 9), follow the floor mounting instructions on page 9 through 12 instead.

Hardware is included with the EUROBED® for attaching to most wall constructions. Follow the instructions on pages 6 to 8 to assure proper installation. Hardware is **not** included for floor attachment.

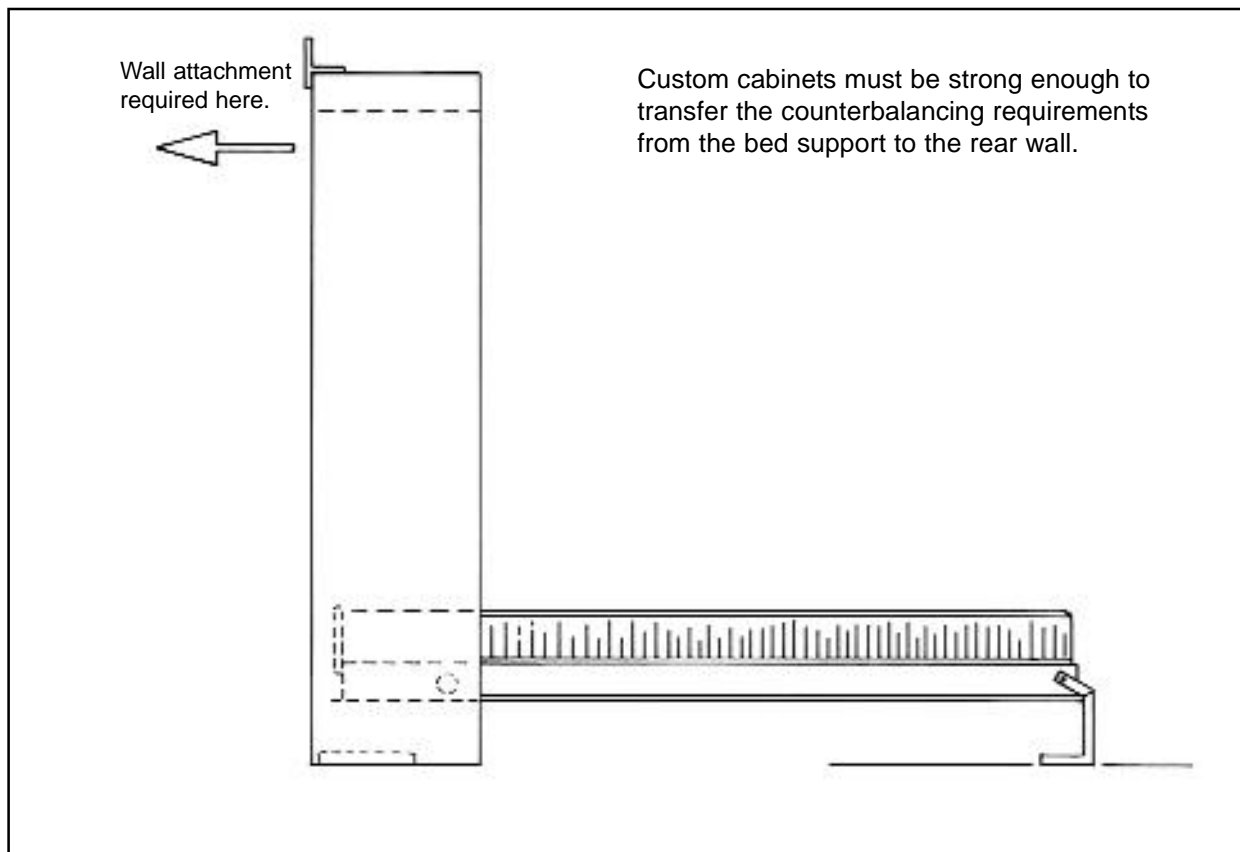

The cabinet and recess sides must be at least 3/4" thick, of wood or woodlike material. **Drywall** is **not** an acceptable material for securing the mounting plates of the bed mechanism.

# GENERAL INFORMATION

**IMPORTANT:** Before you start to install the bed, verify the size of opening required:

Bed Size	Opening Height EUROBED®	Opening Height 24/7	Opening Width
Twin	78-7/8"	--	41"
Twin XL	83-7/8"	--	41"
Double	78-7/8"	86-3/16"	56"
Double XL	83-7/8"	91-3/16"	56"
Queen	83-7/8"	91-3/16"	62-1/2"

If the bed is being installed in a SICO EUROBED® Recess (according to instructions #108450-04), assemble the recess and secure it to the wall, then skip to page 14.

If the bed is being installed in a custom cabinet, begin on page 6.

**IMPORTANT:** When installing the EUROBED® make sure the ceiling clearance is greater than 93". For the EUROBED® 24/7 regular length bed make sure the ceiling height is 95" or greater. For the queen and extra long bed the ceiling height should be 100" or greater.

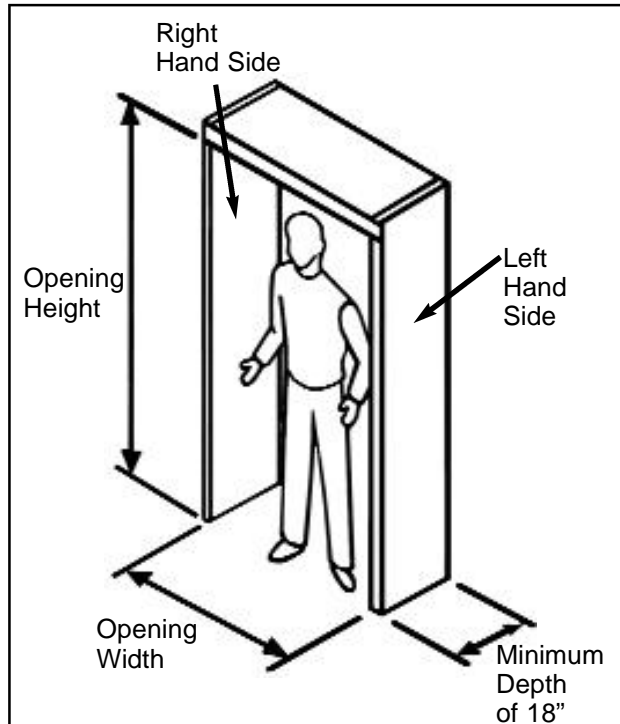

If anything is missing or if you have any questions at installation, contact SICO® Customer Service at 1-800-238-6138.

**NOTE:** The minimum recess depth is 18" for a standard mattress thickness of 10-1/2"; add 1" to the minimum recess depth for each additional 1" of mattress thickness.

For thicker bed faces: the standard bed face is 3/8". For thicker bed faces (raised panel, trim, etc.), mount flush with front of recess, add the difference between the actual bed face thickness and 3/8" to the minimum depth.

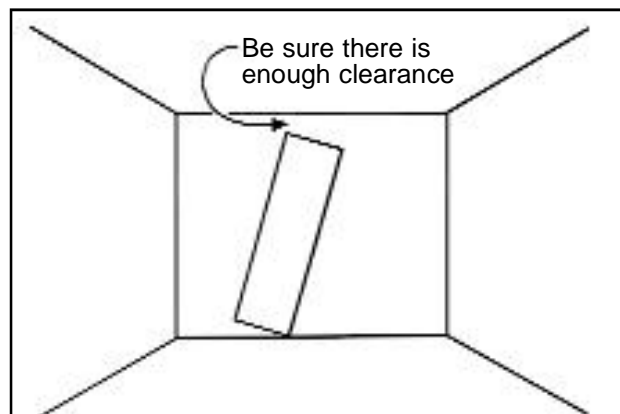

## IMPORTANT

For safety, you *must* use the correct fasteners when anchoring the system to the wall or floor. Refer to this illustration when assembling.



#12 x 1" wood screw, Part No. 118312

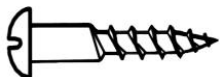

#14 x 1" wood screw, Part No. 103745

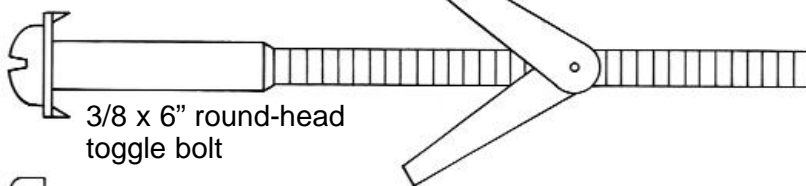

3/8 x 6" round-head toggle bolt

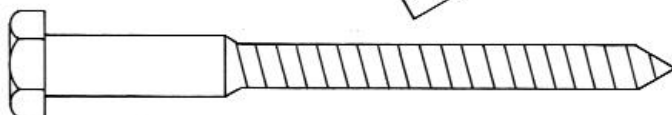

1/2 x 5" hex-head lag screw

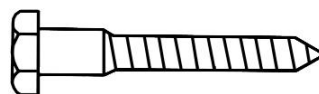

5/16 x 2" lag screw, Part No. 100977

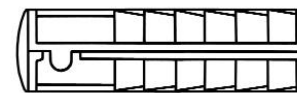

5/16" lag shield (for concrete walls), Part No. 100975

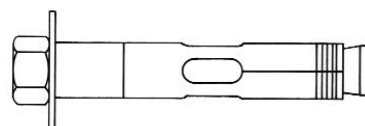

1/2 x 3" expansion anchor

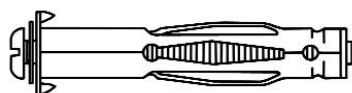

1/4 x 2-1/2" hollow-wall anchor, Part No. 100976

# SECURE RECESS TO WALL

1. Recheck that the unit is level, plumb, and square. Adjust the leveling feet as necessary.

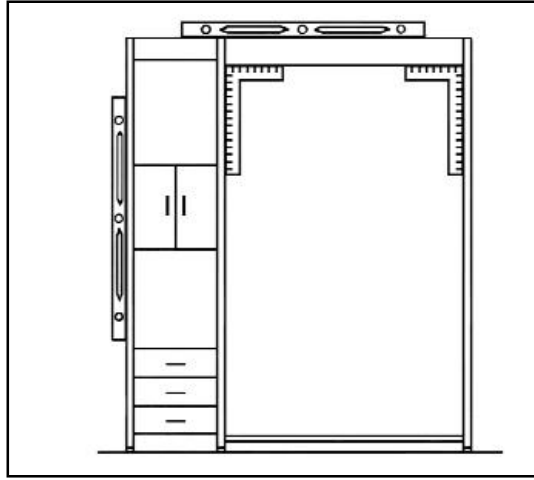

The counterbalancing of a EUROBED® is supported by the weight of the header and cabinets *plus* their attachment to the wall. It is therefore *very important* that the header/cabinet system be anchored securely to the wall, as high off the floor as possible.

If the system cannot or should not be attached to the wall (see step 1 on page 9), follow the floor-mounting instructions on pages 9 through 11 instead.

2. Determine the exact location of all wall studs behind the recess. Use a stud finder (preferably the electronic type).

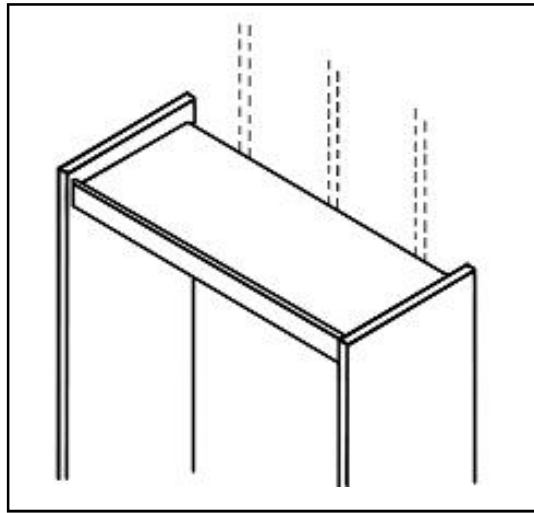

## ⚠ WARNING

**Failure to securely anchor the system according to instructions can allow it to tip over when the bed is operated - which could cause serious injury.**

3. Attach the SICO® wall-mounting fixture to the bed-recess verticals:

- a. Hold the fixture flush with the top and back edges of the verticals, then push it straight back against the wall.
- b. Hold the fixture in this position, and mark the location of the screw holes.
- c. Drill 1/8" dia. pilot holes in both verticals, 3/4" deep.
- d. Attach the fixture to the inside of the verticals with four screws (part number 103745 ) at each end.

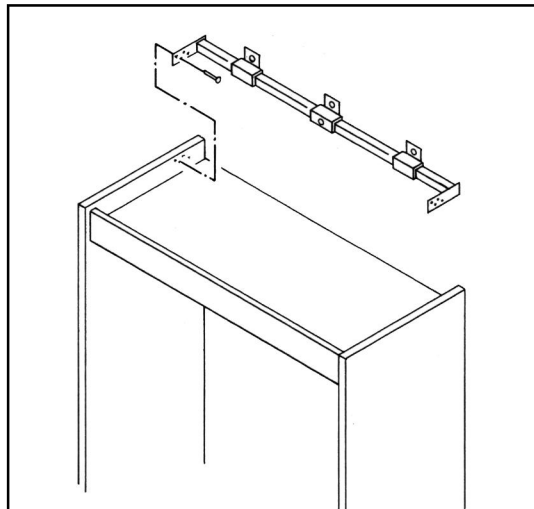

If the fixture must be moved more than 3/4" back beyond the edge of the vertical (because the wall is very uneven or out of plumb), contact the factory before installing.

The wood screws (Part No. 103745) supplied for attaching the SICO wall-mounting fixture and the EUROBED® mechanism plate are intended for verticals which are 1" or more thick. If your verticals are *less* than 1" thick, install washers under the screw heads as necessary.

## Mounting Methods for Wall-Mounting Fixture

(see Step 4 of "Secure Recess to Wall," on page 8)

Select the method below which is appropriate to wall structure.

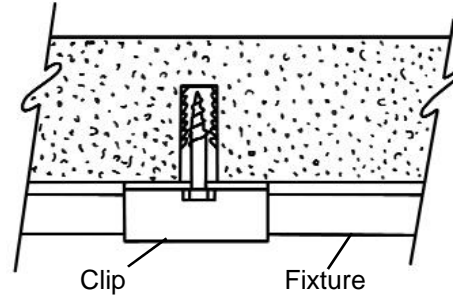
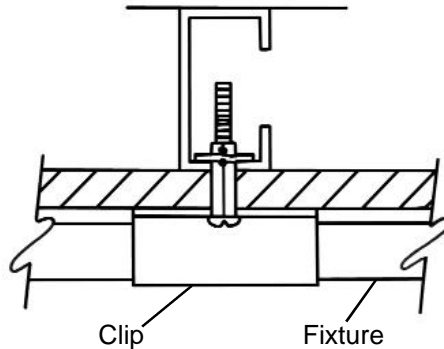
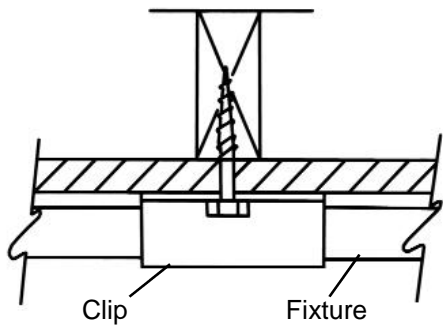

### Wood Studs

**IMPORTANT:** Keep the unit level and plumb during the following procedure.

Set a clip on the wall-mounting fixture as shown, so its hole is centered on the stud (at the location marked earlier).

Mark and drill a 3/16" diameter hole through the clip hole and at least 1-1/2" deep into the center of the stud.

Repeat with the other clip(s).

Check that the unit is still plumb front-to-back and side-to-side, and square.

Attach the clips to the wall with 5/16" x 2" lag screws (Part No. 100977) through the clip hole. Tighten securely.

### Sheet Metal Studs

**IMPORTANT:** Keep the unit level and plumb during the following procedure.

Set a clip on the wall-mounting fixture as shown, so its hole is centered on the stud (at the location marked earlier).

Mark and drill a 7/16" diameter hole through the clip hole and the center of the stud.

Insert a 1/4" x 2-1/2" hollow-wall anchor (Part No. 100976) into the hole, and tighten the screw to expand the anchor.

**Note:** A longer anchor may be required, depending on the wall construction.

Repeat with the other clip(s).

Check that the unit is still plumb front-to-back and side-to-side, and square.

Remove the clip screws from the anchors, then use them to attach the clips to the wall. Tighten securely.

### Concrete Walls

**IMPORTANT:** Keep the unit level and plumb during the following procedure.

Set a clip on the wall-mounting fixture as shown.

Mark and drill a 1/2" diameter hole through the clip hole and at least 2" deep into the concrete. Insert a 5/16" lag shield (Part No. 100975) into the hole.

Repeat with the other clip(s).

Check that the unit is still plumb front-to-back and side-to-side, and square.

Attach the clips to the wall (through the shield) with 5/16" x 2" lag screws (Part No. 100977). Tighten securely.

## SECURE RECESS TO WALL - continued

4. Attach the wall-mounting fixture to the wall. Use the fixture's wall clips and appropriate fasteners (page 7).

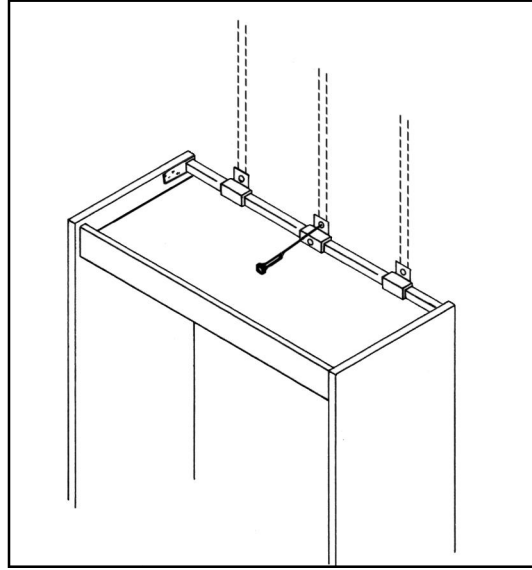

## INSTALL MECHANISM PLATES

1. The recess should already be installed, and 1-3/8" holes should be predrilled in each vertical for the mechanism plate.  
Position a mechanism plate in the 1-3/8" holes of each vertical as shown.
2. Drill a 1/8" diameter pilot hole in each screw location, then attach the mechanism plate to the vertical with five #14x1" Phillips-head wood screws.

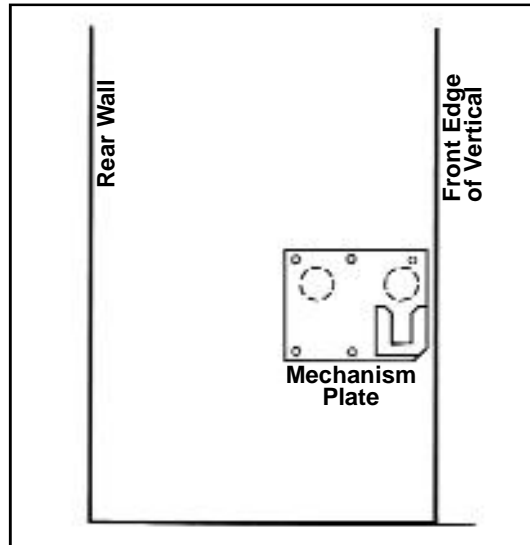

If using verticals other than those available from SICO<sup>®</sup>, refer to the drilling template shipped with each bed. It provides instructions on drilling 1-3/8" holes in the surface of the verticals for the mechanism plates.



## SECURE BASEPLATE TO FLOOR (if required)

1. The baseplate **must be securely attached** to the floor in the following situations:

- When installing the recess against a partition;
- When installing the recess against a portable wall.

If the baseplate **will** be secured to the floor, refer to the appropriate floor anchoring instructions on the next four pages. Especially on plush carpet, be sure the baseplate is pulled down tightly to the floor.

**Important:** Score / cut carpet before drilling for anchors. This will prevent the carpet from fraying.

If the baseplate **will not** be secured to the floor, go to page 13.

2. After securing the baseplate to the floor, temporarily attach the brackets to the baseplate as shown. With the brackets in place, mark the location of the sleeve which is on the upper end of each bracket.

If holes do not exist, remove the brackets and drill a 1-3/8" dia. hole 1/2" deep as shown.

Reinstall the brackets.

3. Tighten the brackets to the baseplate using two hex nuts and washers. Drill a 1/8" diameter pilot hole in each screw location, then attach the brackets to the vertical with three #14 x 1" wood screws.

After the baseplate is attached to the floor, and the brackets are secured to the baseplate and verticals, go on to page 14.

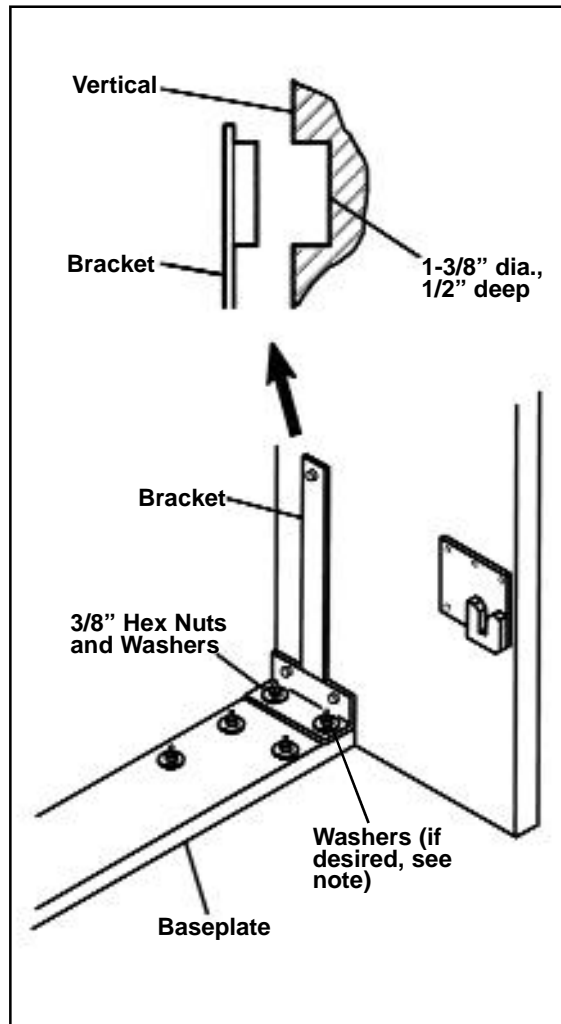

### **⚠ WARNING**

**Failure to securely anchor the system according to instructions can allow it to tip over when the bed is operated - which could cause serious injury.**

**IMPORTANT:** For safety, follow these instructions carefully and in the order given.

**NOTE:** On floor mounted installations only, add washers as required to fill the gap between the base plate and bracket.

**▲ WARNING**

**DO NOT floor mount the bed on top of post tension concrete. If you are unsure of the concrete, have the floor x-rayed or check with the architect. Serious injury and damage to the unit can occur.**

**▲ WARNING**

**If the bed must be securely anchored to the floor (see page 9): Failure to follow instructions may cause the baseplate to release, which could cause serious injury.**

**FLOOR ANCHORING-**

**Hard Concrete Slab Floors**

**NOTE: Anchors for hard concrete slab floors are provided with the bed. Use six anchors per bed. Use anchors appropriate to the type of floor: SICO® recommends Red Head #HN-1230 1/2 x 3" Expansion Anchors, or their equivalent.**

1. Have the baseplate in position before installing anchors.
2. At the first anchor location, drill a 1/2" diameter hole straight down through the baseplate and at least 2-3/4" into the concrete. You may have to drill a 1/4" diameter pilot hole, then enlarge it to 1/2".

Do not allow the drill to rotate and hammer on the hard aggregate, or the hole may become enlarged. If this happens, refer to the procedure for "Lightweight Concrete Floors" on page 11.

3. Install the washer onto the anchor bolt (see note above), then install the nut one turn.

Drive the anchor into the hole.

**IMPORTANT: The anchor must extend at least 1-3/4" into the concrete.**

4. Tighten the nut on the anchor. If you don't feel firm resistance on the wrench, the anchor isn't seating or locking properly (the floor may be lightweight concrete - see page 11).

If you anchor bolt didn't tighten, or if you met an obstacle such as a reinforcing bar, drill a new hole through the baseplate and into the concrete, 1-1/2" away from the existing hole.

5. Repeat steps 2 through 4 for the other anchors.

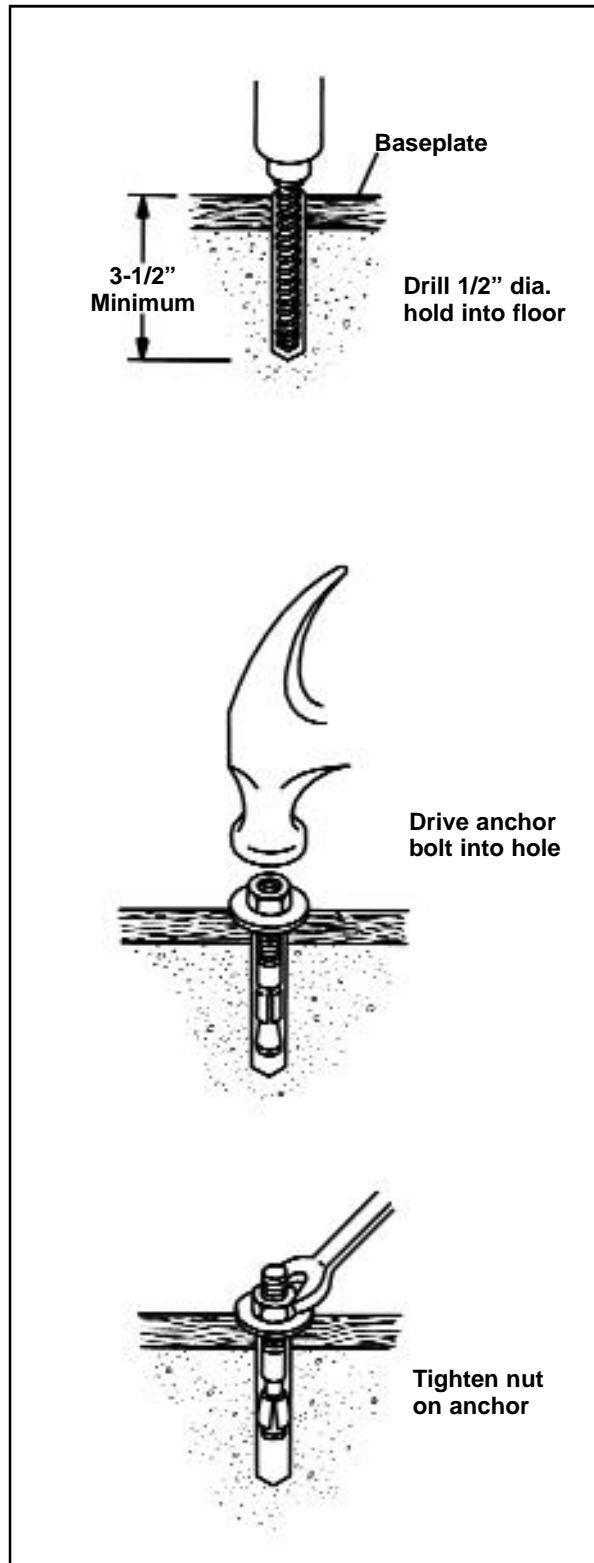

**NOTICE: SICO does not recommend using power-driven or nonexpanding type anchor bolts (those forced in with compressed air or an explosive charge) to secure the baseplate to the floor.**

**Anchors and washers are in the Small Parts Package marked "102082."**

**If you encounter any problem or a unique floor construction, contact SICO Customer Service at 1-800-328-6138.**

**IMPORTANT: Especially on plush carpet, be sure the baseplate is pulled down tightly to the floor.**

**Do not continue with the bed installation unless all anchors are properly installed and tightened.**

**⚠ WARNING**

**If the bed must be securely anchored to the floor (see page 9): Failure to follow instructions may cause the baseplate to release, which could cause serious injury.**

**FLOOR ANCHORING-**

**Wood, Lightweight Concrete, Thin Concrete over wood, Metal Deck, and Miscellaneous Floors**

**NOTE: Use anchors appropriate to the type of floor: SICO recommends the Star 3/8 x 6" roundhead toggle bolts or their equivalent. These toggle bolts are not supplied with the bed. Use six anchors per bed.**

1. Have the baseplate in position before installing anchors.
2. At the first anchor location, drill a 1" diameter hole through the baseplate and floor.

If you encounter a joist, or if a wood floor won't support any type of anchor, follow the procedure under "Joists," page 12.

3. Assemble a 1-1/2" diameter washer onto a 3/8" diameter toggle bolt. Insert the toggle bolt through the hole.
4. Repeat steps 2 and 3 for the other anchors.
5. Tighten the toggle bolts with a flat-blade screwdriver.

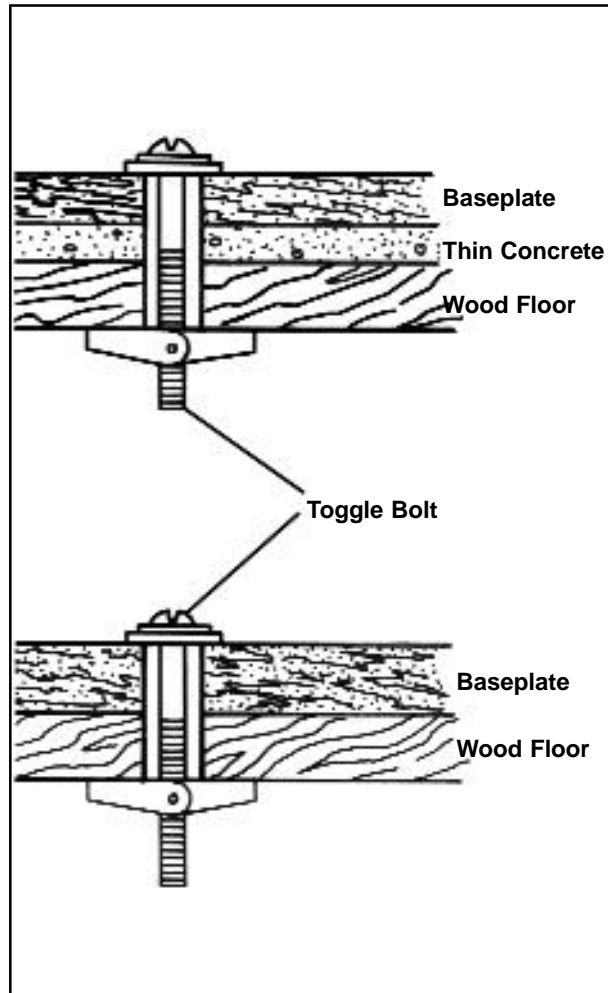

If you encounter any problem or a unique floor construction, contact SICO® Customer Service at 1-800-328-6138.

**IMPORTANT: Especially on plush carpet, be sure the baseplate is pulled down tightly to the floor.**

**Do *not* continue with the bed installation unless all anchors are properly installed and tightened.**

**▲ WARNING**

**If the bed must be securely anchored to the floor (see page 9): Failure to follow instructions may cause the baseplate to release, which could cause serious injury.**

**FLOOR ANCHORING-  
Joists**

If you encounter a joist at the anchoring location, use the following procedure. Note that **toggles are preferred for anchoring the baseplate**, so the following procedure should be used only if unavoidable.

**NOTE: Floor anchors for wood joists are not provided with the bed. Use six 1/2" x 5" hex-head tag screws (available from any hardware store).**

1. Have the baseplate in position before installing anchors.
2. At the first anchor location:

**Floors of Lightweight Concrete Over Wood.** Drill a 3/8" diameter pilot hole through the baseplate and concrete. Then drill a 7/32" diameter pilot hole into the joist.

**Wood Floors.** Drill a 7/32" diameter pilot hole through the baseplate and floor, into the joist.

3. Use 1/2" diameter lag screw and large washers. The screw must be long enough so that at least 2" of it penetrates the joist.

Install the lag screw and tighten it down securely.

4. Repeat steps 2 and 3 for the other anchors.

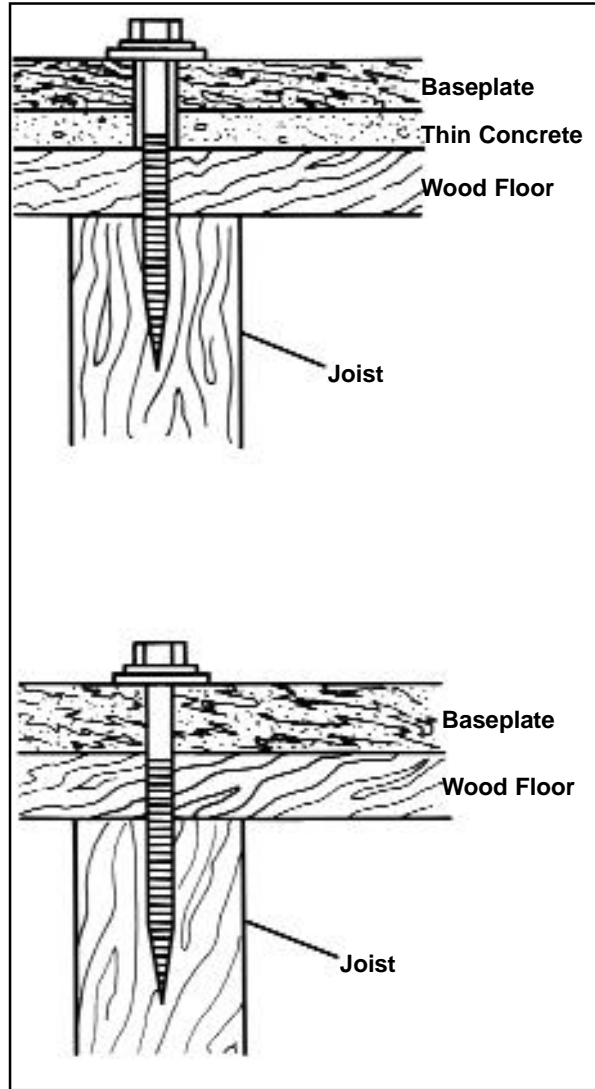

If you encounter any problem or a unique floor construction, contact SICO® Customer Service at 1-800-328-6138.

**IMPORTANT:** Especially on plush carpet, be sure the baseplate is pulled down tightly to the floor.

**Do not** continue with the bed installation unless all anchors are properly installed and tightened.

## INSTALL BASEPLATE (if not secured to the floor)

**NOTE:** See step 1 on page 9 to determine if the baseplate should be secured to the floor.

1. Set the baseplate in the recess opening. The side with four holes must be toward the rear wall.

Remove the hex nuts and washers from the four carriage bolts in the baseplate.

2. On each end, slide the baseplate bracket down over the bolts.
3. Temporarily attach the brackets to the baseplate as shown. With the brackets in place, mark the location of the sleeve which is on the upper end of each bracket.

Remove the brackets and drill a 1-3/8" dia. hole 1/2" deep as shown. Reinstall the brackets.

4. Tighten the brackets to the baseplate using two hex nuts and washers. Drill a 1/8" diameter pilot hole in each screw location, then attach the brackets to the verticals with three #14 x 1" wood screws.

Go on to page 14.

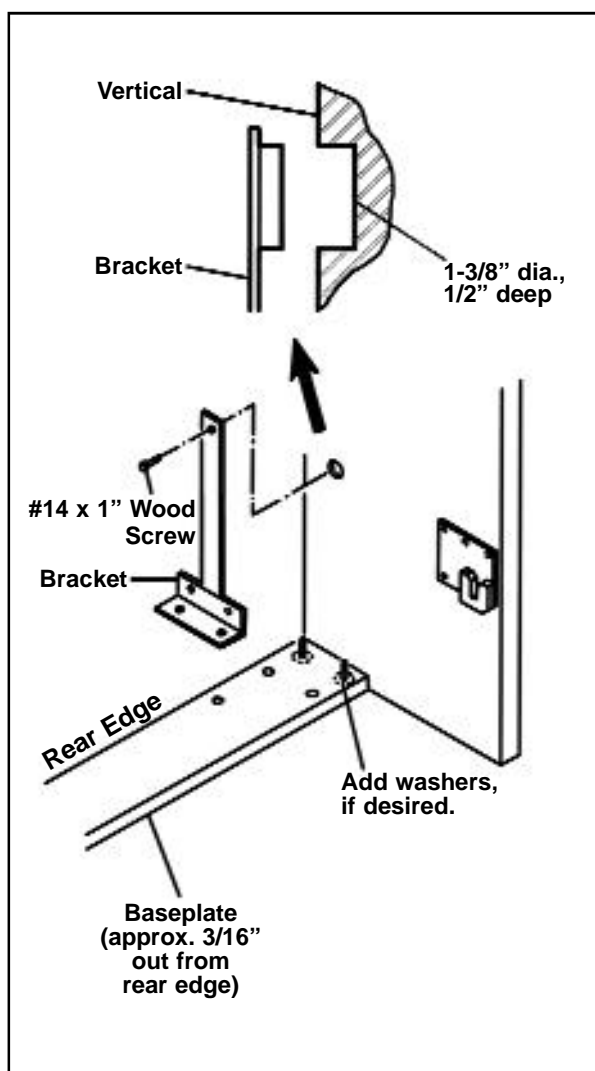

# ATTACH MISCELLANEOUS PARTS TO BED

NOTE: For thicker bed faces: the standard bed face is 3/8". For thicker bed faces (raised panel, trim, etc.), mount flush with front of recess, add the difference between the actual bed face thickness and 3/8" to the minimum depth.

1. With a pencil, mark the hole location for a stop bumper on the inside edge of each vertical, where indicated. Drill a 1/8" diameter hole 1/2" deep.

Attach the bumpers with #12 x 1" Phillips-head wood screws.

2. If the bed was purchased with "no face," attach the desired face at this time. Instructions are in the bag marked "104358."

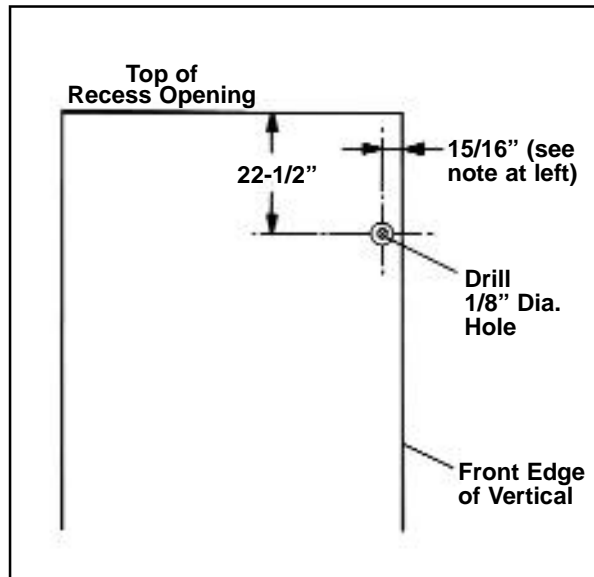

Bumper and screw are in the accessory pack marked "107524."

3. Remove the two 5/16 x 1" hex-head cap screws and nuts from the headboard support brackets. Install a flat washer on each screw, insert the screws through the brackets and bed frame, then secure with a lockwasher and nut.

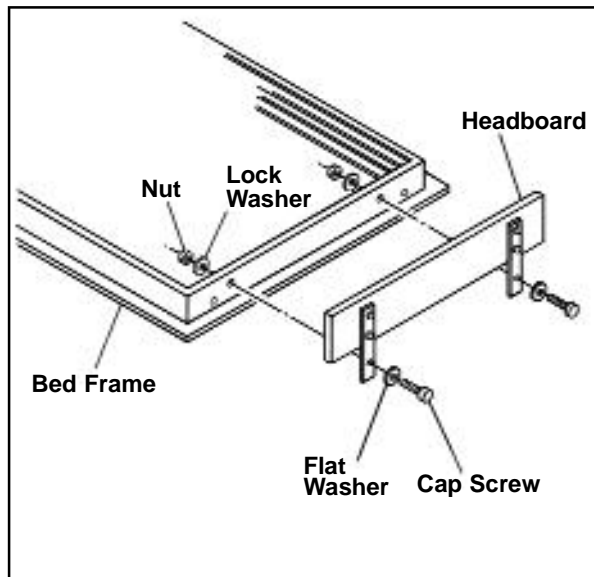

4. Using the pilot holes through the bed frame as a guide, drill two 3/32"-diameter pilot holes through the bed face on each side, for the handles.

Once these are drilled, use a 3/16"-diameter bit and drill (from the **face** side) through the pilot holes.

Attach the handles with two #8 x 3/4" Phillips-head machine screws.

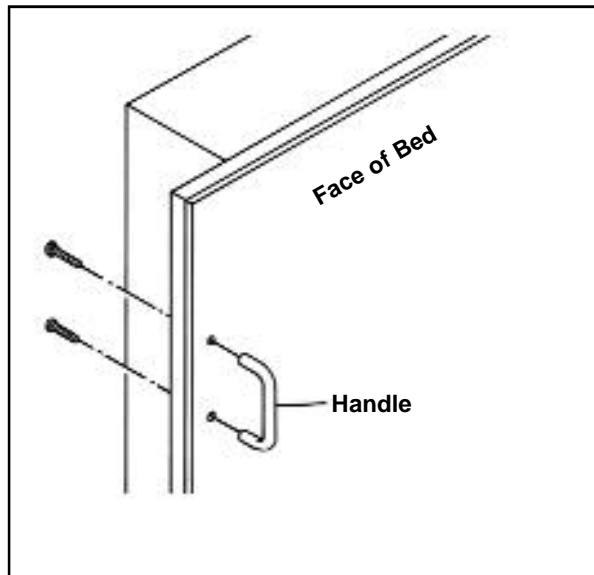

Handles and screws are in the accessory pack marked "107524."

A piece of masking tape on the face where the holes are to be drilled will help prevent chipping.

## ▲ CAUTION

Be careful handling the frame once the handles are installed. The handles are *not* designed to carry the full weight of the bed.

# INSTALL EUROBED® IN RECESS

1. Back off the mechanism adjuster nuts fully.
2. For the 24/7 EUROBED®, install toe-kick with brackets and wood screws at the bottom of the recess opening. The bottom edge of the toe-kick is even with the bottom edge of the vertical (see 24/7 EUROBED® specification sheet for location of the toe-kick).

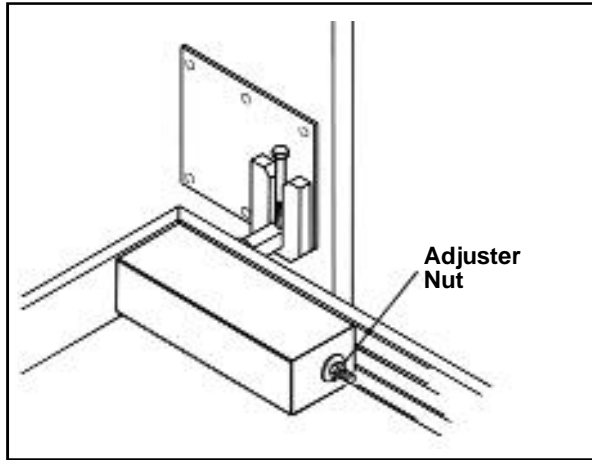

## ⚠ CAUTION

*Two people are required at all times when placing the bed into the recess. Be very careful to keep your arms and fingers out of the space between the bed frame and the edge of the verticals.*

3. With one person on each side, lift the bed frame to a nearly-vertical position. Lift with one hand on a slat and the other hand on the outside against the face of the bed.
4. Keep your back braced against the front of the recess, and **very carefully** lift the bed into the recess opening - making sure you don't strike either the side or top edge of the recess or toe-kick. Keep the bed nearly vertical.

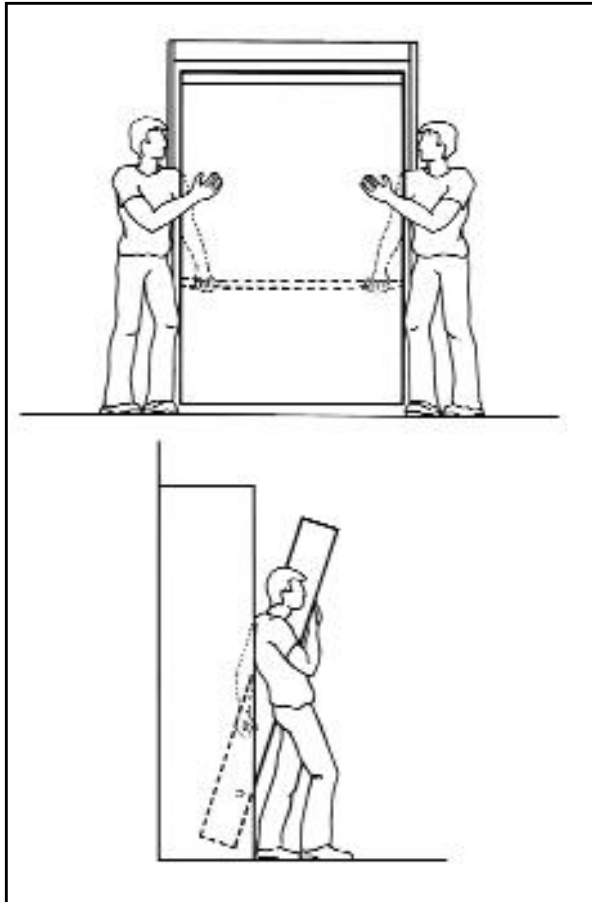

5. Lift the bed so the shafts rest on the front edge of the mechanism plates. Gently lower the bed into the slots in the mechanism plate.

**NOTE: Both pivot shafts should go into their slots at the same time. Lowering one at a time may damage the vertical or header.**

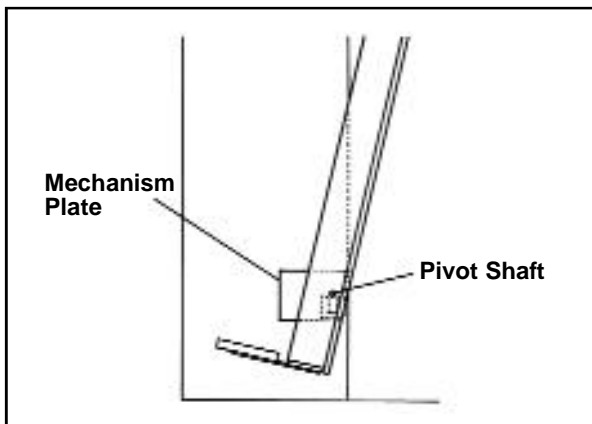

## INSTALL EUROBED® IN RECESS (continued)

6. Check the alignment of the bed and recess. If the side gaps are not equal (about 1/4" each), insert a large flat-blade screwdriver between the edge of the bed frame and the mechanism plate. **Do not push** against the edge of the vertical, or it may be damaged.

Push the screwdriver in the direction that the bed must be moved.

Once the bed is centered, drop a flat washer (or a penny) between the end of the shaft and the edge of the mechanism plate to prevent sideways movement.

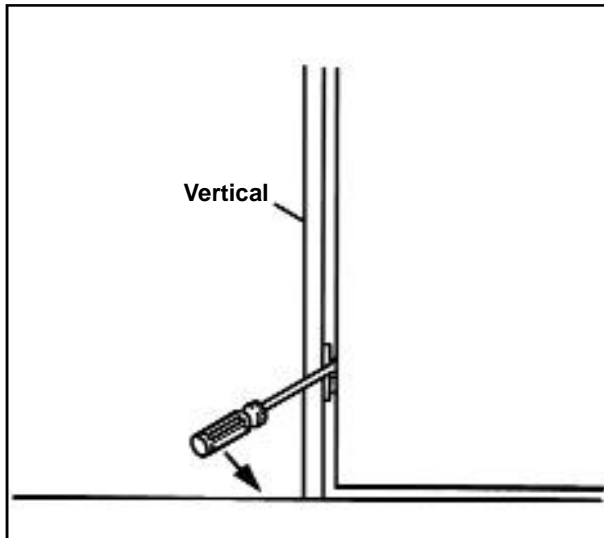

7. With the bed in the nearly-vertical position, adjust the gap at the top of the recess by turning the adjuster bolt in the pivot shaft:

- Clockwise to raise the bed in the recess, or
- Counterclockwise to lower the bed in the recess.

The final gap on top should be about 3/8" for EUROBED® and 1-5/16" for the 24/7 EUROBED®.

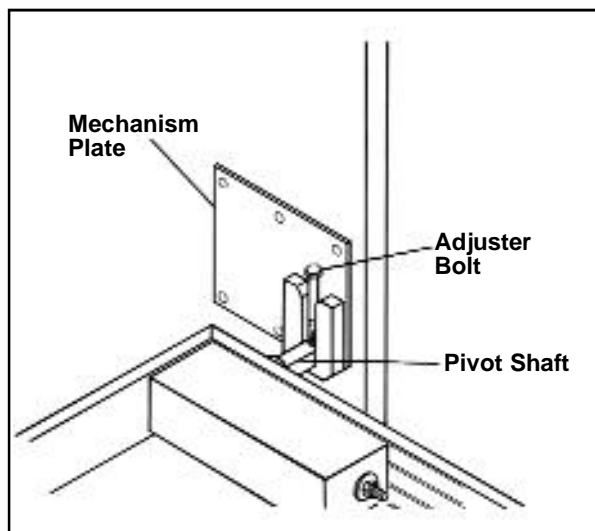

8. With the bed still in the nearly vertical position, tighten the mechanism adjuster nuts as far as possible **by hand**.

Install the mattress, and check the operation of the bed. Raising the bed should require only moderate pressure. If it is hard to raise, tighten the adjuster nuts by equal amounts until the bed operates satisfactorily. Use a 3/4" deep socket for final adjustment.

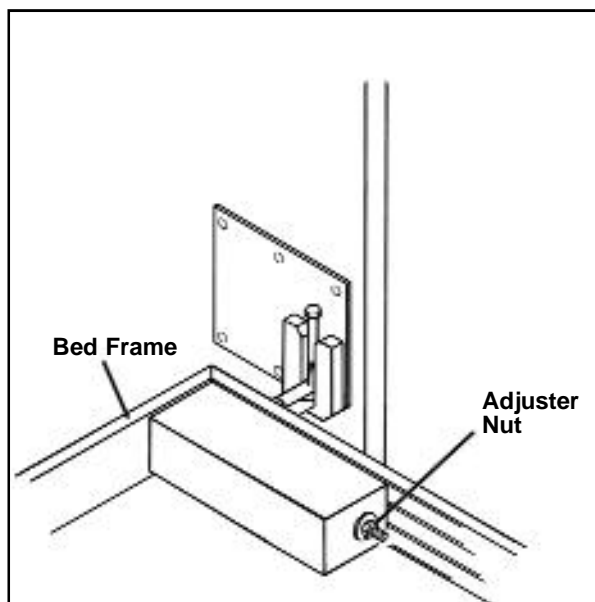

### IMPORTANT

For easy identification of parts, the bed is shown **down** in the illustrations for steps 5 and 6.

**DO NOT** make these adjustments when the bed is down - adjust the nuts **only** when the bed is in the **nearly-vertical** position.



# PARTS LIST

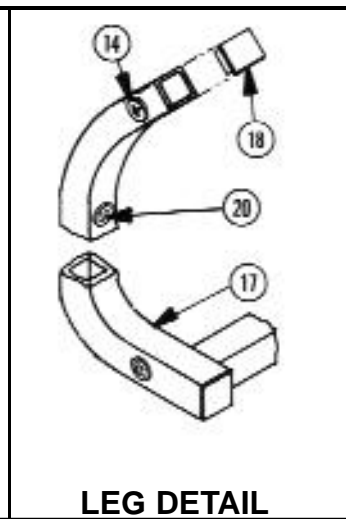
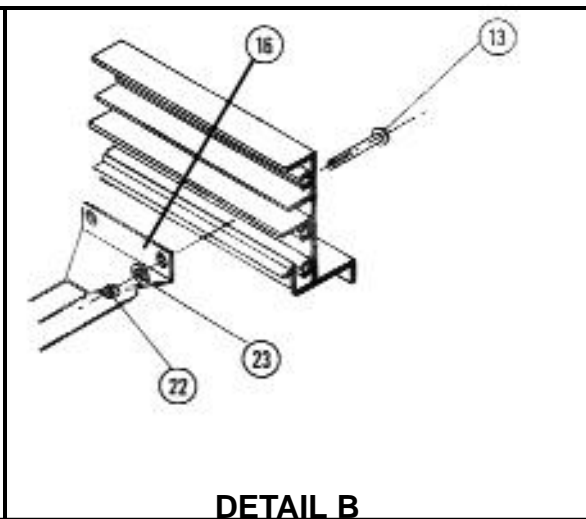
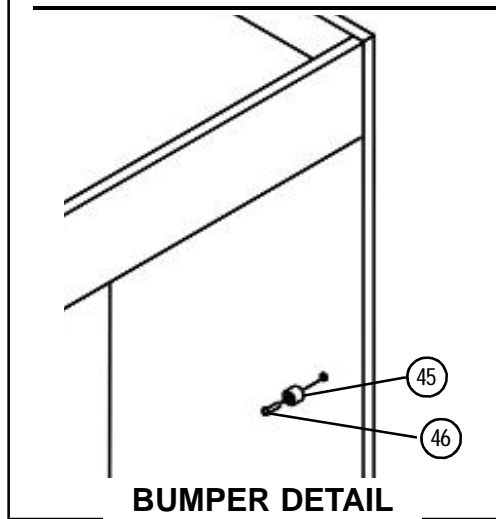
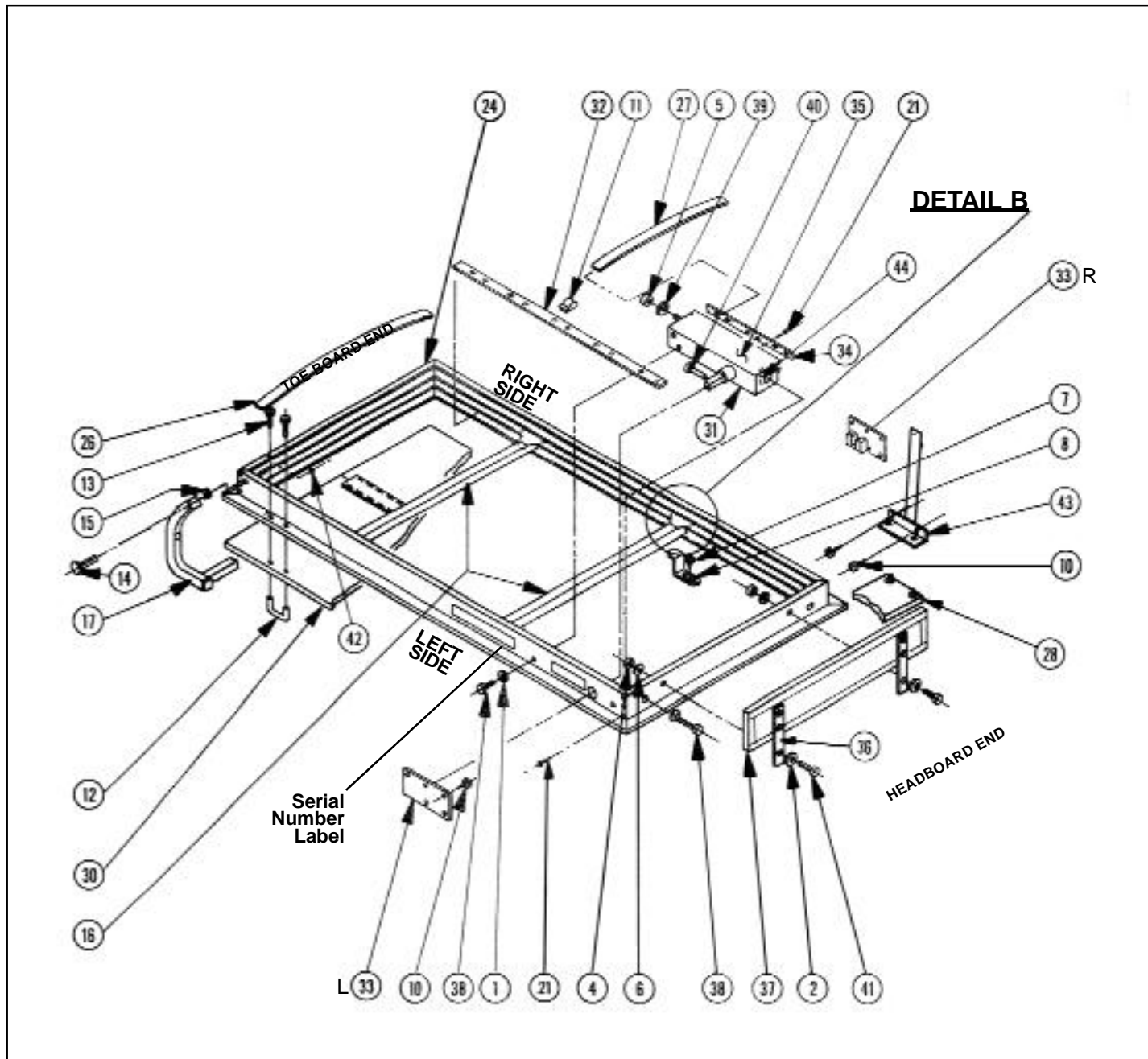

**PARTS LIST (continued)**

<b>ITEM NO.</b>	<b>DESCRIPTION</b>	<b>ITEM NO.</b>	<b>DESCRIPTION</b>
1	Washer, flat, 3/8"	27	Slat, short
2	Washer, flat, 5/16"	28	Baseplate assembly
4	Nut, hex, 5/16-18	30	Face, bed
5	Nut, hex, 1/2-13	31	Mechanism
6	Washer, lock, 5/16"	32	Retainer, slat (long)
7	Screw, sheet metal, #12 x 3/8"	33R	Plate, mechanism, right-hand
8	Clip, bed face	33L	Plate, mechanism, left-hand
10	Screw, #14 x 1"	34	Retainer, slat (short)
11	Clip, Tinnerman	35	Cover, mechanism
12	Handle	36	Support, headboard
13	Screw, machine, round-head, 8-32 x 3/4"	37	Headboard assembly
14	Screw, machine, Phillips truss-head, 1/4-20 x 1-1/2"	38	Screw, cap, hex-head, 3/8-16 x 1-1/4"
15	Washer, flat, 1/4"	39	Washer, flat, 1-3/8" OD
16	Crossrail assembly	40	Bolt, tap, hex-head, 3/8-16 x 2"
17	Leg assembly	41	Screw, machine, hex-head, 5/16-18 x 1"
18	Cap, 3/4" square tube	42	Nut, stop, 1/4-20
20	Bumper	43	Bracket, baseplate
21	Screw, particleboard, #8 x 1"	44	Nut, weld, 3/16-16
22	Nut, lock, 8-32	45	Screw, wood #12 x 1
23	Washer, flat, 3/16"	46	Bumper, rubber
24	Bed frame assembly		
26	Slat, long		

Specify bed size (twin, twin XL, double, double XL, queen) and height (EUROBED®, 24/7 EUROBED®, custom)

Order by Item Number. Specify "for EUROBED®."

Always provide the Serial Number of the bed when ordering parts.

SICO Incorporated reserves the right to substitute materials or make changes if materials are not available and such changes improve the product.

**Visit our website at [www.sicoinc.com](http://www.sicoinc.com)**

<p><b>The Americans</b> SICO America Inc. USA In U.S., phone (800) 328-6138 Outside U.S., (952) 941-1700 Fax: (952) 941-6688 E-mail: <a href="mailto:sales@sicoinc.com">sales@sicoinc.com</a></p>	<p><b>Europe</b> SICO Europe LTD. England Phone [44] (1303) 234000 Fax: [44] (1303) 234001 E-mail: <a href="mailto:sales@sicoeurope.com">sales@sicoeurope.com</a></p>	
<p><b>Spain &amp; Portugal</b> Sistemas SICO S.L. Spain Phone [34] (91) 358-9076 Fax: [34] (91) 358-9264 E-mail: <a href="mailto:sales@sistemas-sico.com">sales@sistemas-sico.com</a></p>	<p><b>Australasia &amp; South Africa</b> SICO South Pacific Australia Phone [61] (2) 4388-5100 Fax: [61] (2) 4389-1341 E-mail: <a href="mailto:sales@sicosp.com.au">sales@sicosp.com.au</a></p>	
<p><b>Japan</b> SICO Nippon Co., LTD Japan Phone [81] (3) 3791-2277 Fax: [81] (3) 3791-3300 E-mail: <a href="mailto:siconpn@apricot.ocn.ne.jp">siconpn@apricot.ocn.ne.jp</a></p>	<p><b>Asean Countries/ Korea &amp; India</b> SICO Asia PTE LTD. Singapore 118535 Phone [65] 6472-2633 Fax: [65] 6472-2600 E-mail: <a href="mailto:sales@sicoasia.com">sales@sicoasia.com</a></p>	<p><b>China</b> SICO-SST China Phone [86] (10) 6467-9126 Fax: [86] (10) 6466-4815 E-mail: <a href="mailto:sales@sico-sst.com">sales@sico-sst.com</a></p>