

SICO® Deluxe Catering Table

A mobile folding catering table with an upscale design.



Features, Advantages & Benefits

SICO® ARMOR-EDGE®

- The most durable edge available.
- Provides an incredibly tough edge to take hard everyday abuse without damage.
- Hermetically seals the tabletop and bench edges for sanitary purposes.
- Allows for easy clean-up, including steam cleaning.
- Proven track record for long-term durability.

High-pressure Laminate

- Tough .04" (.10cm) thickness high-pressure laminate for added durability and long-term wear.
- Sanitary and easy-to-clean.
- A large variety of striking colors and patterns are available to fit any color scheme.

Solid MDF Core

- Laminate tops are made with extremely durable ¾" MDF core material that is stronger than plywood or particleboard and resists warping.
- MDF core out-performs plywood or particleboard, is light-weight and resists warping.

Rigid Vinyl Backer Sheet

- Applied to the underside of the tabletops for moisture control and easy cleanup (including gum removal), stain resistance and fantastic appearance.
- Far superior to all types of paper backers.

Tamper Proof Expansion Rivets – Fastens tabletop firmly to the frame and won't work loose like ordinary screws.

Aircraft Lock Nuts - Superior construction. Aircraft lock nuts are used at all pivot points so they stay in place through years of use.

Hydraulic Damper Folding Mechanism –

- Entire table top folds up and down for compact storage and use configurations.
- Hydraulic damper ensures a slow, smooth fold into storage position.
- Protective rubber bumper protects table top when tables are nested together for storage.

Secure Locking Mechanism - 2nd tier releases from locked position and folds down onto 1st tier. Spring-loaded latch and catch auto lock keeps top tier surface secure in use position.

Elliptical Surface - Curved elliptical style top edge design offers an aesthetic upscale look. A spacious upper two-tier and lower tier surface provides more table surface space.

Upscale Design

- A table so elegant, it doesn't require linen or skirting.
- Heavy-duty *black powder coated* oval tubular frame finish.
- New *oval tube frame* gives an upscale look, as well as scratch resistance, strength and stability.
- *Double Cross Member Construction* provides added strength and durability.

Dual-wheel Casters - Non-marring 3" (2.6cm) dual-wheel swivel casters roll quietly while protecting the floor. Two front mounted casters lock to ensure table stays in place.

Free Space Analysis - Take advantage of the free space analysis drawings which will provide you with the appropriate number of tables and table accessories.

Warranty – Protected by a **3-Year Warranty** against manufacturer's defects. **Lifetime Warranty** on welds.

Specifications

Single-Tier Deluxe Catering Table

Tabletop: 72" x 32" (183cm x 81cm)
Table Height: 30" (76cm)
Table Weight: 110 lbs. (50kg.)
Model Number: TB322GSG??02B

Two-Tier Deluxe Catering Table

Tabletop 1st-Tier: 72" x 32" (183cm x 81cm)
Tabletop 2nd-Tier: 72" x 17" (183cm x 43cm)
Table Height: 30" (76cm)
Table Weight: 152 lbs. (69 kg.)
Model Number: TB222GSG??02B

Laminate Options



Wild Cherry
(49)



Bannister Oak
(10)



Nepal Teak
(74)



Kensington
Maple (77)



Gray Nebula
(38)



Graphite
Nebula (50)



Windswept (51)



Saffron Tigris
(54)



Navy Legacy
(53)



Green Tigris
(76)



Karratha Brush
(70)



Maroochy
Brush (71)



Woolamai
Brush (72)

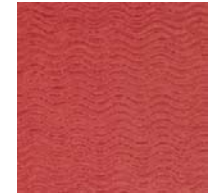

Pomegranate
(78)

* Check with a SICO Representative for additional laminate choices available.

Table Top Armor-Edge Options



Black (02)



Gray (03)



Burgundy (04)



Blue (05)



Brown (06)



For More Information Visit: http://www.sicoinc.com/upscale_catering_table.php

7525 Cahill Road, Minneapolis MN 55439

1.800.533.7426

SICO® Deluxe Catering Table Dimensions

Single-Tier Deluxe Dimensions

Top Height: 30" Folded Height: 40 1/2" Table Top Size: 72x32"



Table Dimensions

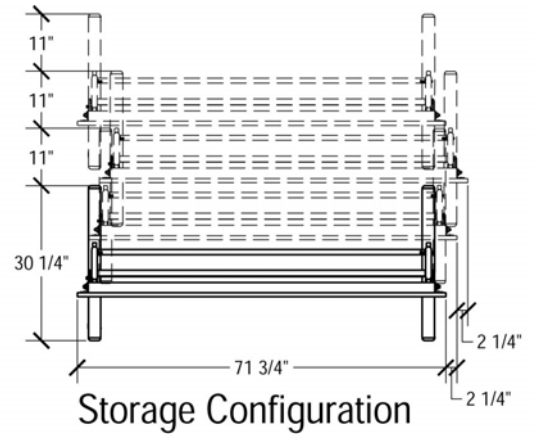

Storage Configuration

Two-Tier Deluxe Dimensions

Top Height: 30" Folded Height: 40 1/2" Table Top Size: 72x32" Upper Tier: 15"dx12"h

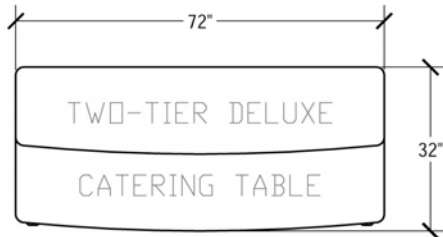
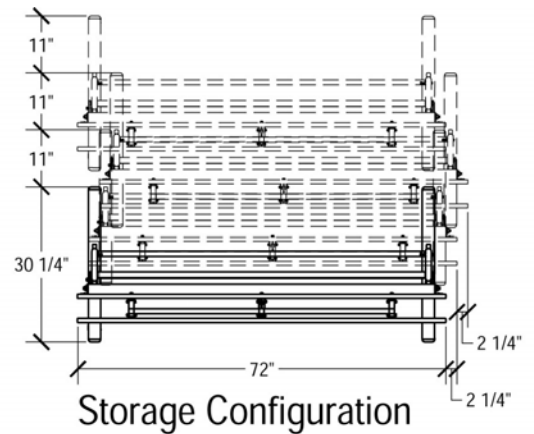

Table Dimensions



Storage Configuration



For More Information Visit: http://www.sicoinc.com/upscale_catering_table.php
7525 Cahill Road, Minneapolis MN 55439
1.800.533.7426