



SICO AMERICA INC.  
7525 Cahill Road  
Minneapolis, MN 55439, USA

Customer Service:  
1-800-424-0796  
Website: [www.sicoinc.com](http://www.sicoinc.com)

# LB TABLE OPERATING INSTRUCTIONS

## TO OPEN



**1** Release transport lock. Grasp both tops low and force outward.



**2** As table opens, ease downward.



**3** Align table in position before legs reach the floor.

## TO FOLD



**1** Standing at center of table, grasp tops with each hand.

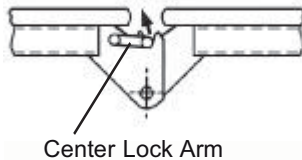

**2** Raise center lock arm and hold against table top. Grasp top and lift table slightly.



**3** Raise table with a continuous upward motion. Lift with your legs.



**4** Grasp tops low and push together until transport lock engages pin.

### When Ordering:

**All Parts.** Indicate table Serial No., height, length, Serial No. is on frame, near center of table.

**Tops.** Indicate color, size

**Legs and Center Frames.**

Indicate table height and leg/center frame finish and color

**For parts or pricing, contact your local dealer or SICO Customer Service.**

### MAINTENANCE:

Oil pivot points every six months. Wash tops with soap and water.

Item	Description
1	Nut Stop .38-24
2	Torsion Bar Assembly
4	Tension Bar
6	Top
7	Center Leg Weldment
8	End Leg Weldment
9	Center Leg Weldment
10	Top Frame Weldment
12	Screw C HH .38-24x1.25
13	Torsion Bar
14	Drive Screw
21	Rivet Drive .25 x .53
22	Screw C HH .38-24 x 1.00
23	Push Nut .38 Cup
24	Push Nut .38 Washer
25	Glide Cap Round 1.00
30	Push Nut Washer .50
32	Lock Arm 1/2 Diameter
33	Swivel Caster, 4"
34	Screw C HH .38-24 x 2.25
35	Screw C HH .38-24 x 2.00
36	Screw C HH .50-13 x 1.00
37	Screw C HH .38-24 x 4.50
38	Flat Washer .53 x .88
39	Nut Stop .50-13
40	Acorn Nut .50-13
43	Plug Square .88 x 16ga.
44	Washer L Spring

Item	Description
47	Spacer .50 x .50
49	Glide Cap Round 1.00
50	Plug Square 1.00 Angled
57	Lock rod
58	Hook
59	Vinyl cap, 5/8

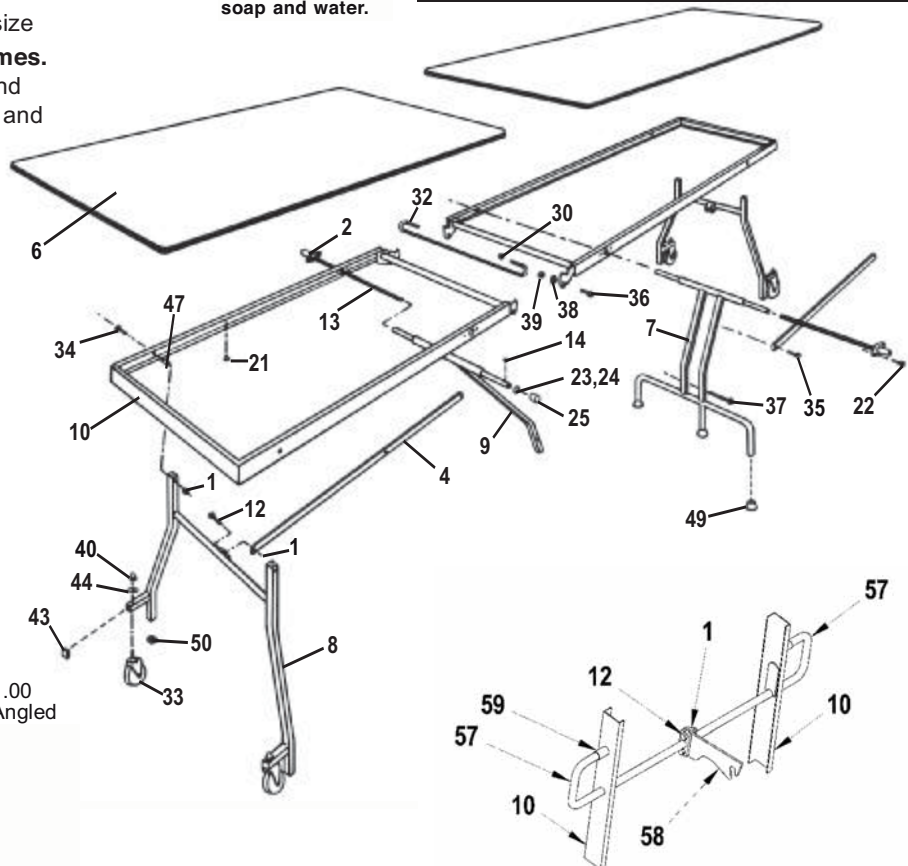

## WARNING

To be moved and operated only by an adult.

Before moving, engage the transport lock to prevent tipping.

Failure to follow warnings may result in serious injury or death.

## TO ROLL

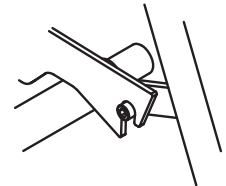

Engage hook before moving.

## WARNING

To avoid table tipping over, push from end of table. DO NOT push from side.

Avoid debris on floor.